

Gas condensing wall-hung boiler Innovens MCA PRO 45-65-90-115

1. Marketing

2. Range

3. Options

4. Prescription



A proved technology in a new design

De Dietrich 

1. Marketing Sales leaflet

Strong points

- **Very Low NOx and CO emissions**
- **Low noise operating level**
- **Cascading up to 10 boilers**
- **Easy access and maintenance**
- **Well-kept finish**
- **Hydraulic kit of connecting in cascade up to 4 boilers**

The performances

- Annual operating efficiency up to 110%
- Class of efficiency ****CE
- Emissions

CO	< 21,5 mg/kWh
NOx	< 45 mg/kWh
- Classification Class 5 according to EN 297 Pr A₂

Burner

- **Total premix burner of stainless steel with braided metal fibre surface**
 - Modulating from 18 to 100 %
- **Perfect adaptation of the power to the needs of the installation**
- **Energy saving**
 - Silencer on the air aspiration
- **Low noise operating level**
 - Very low NOx and CO2 Emissions

Conservation of the environment

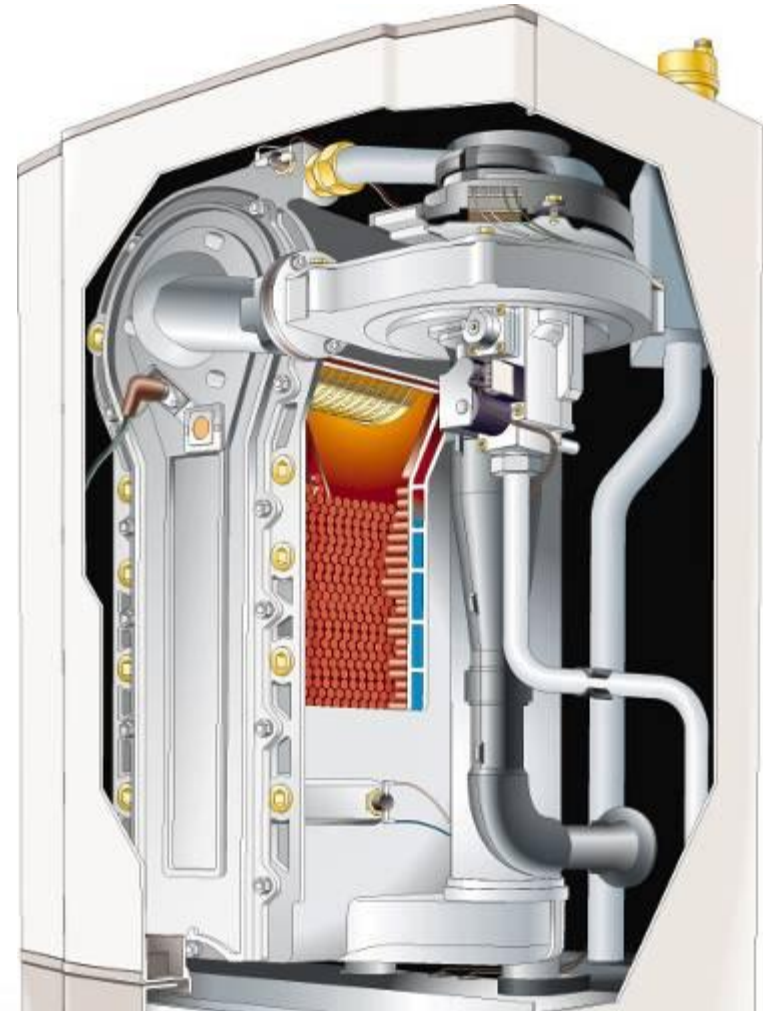

Heat exchanger

- Alloy aluminium/silicone
 - great corrosion resistance
 - Reduced weight
- new mono-block design
 - compact construction
- Great heat-transfer surface
 - high efficiency
- 3 dimensions
 - MCA 45, MCA 65, MCA 90,115
- Very weak pressure loss
- no minimal flow irrigation
- Easy maintenance: access by the front



Heat exchangers of MCA boilers



Diematic iSystem : The design

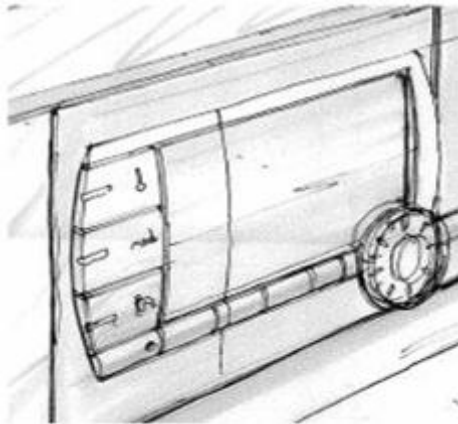

- A modern design
- New display LCD extra-large of 10 x 5,5 cm
40% more surface / Diematic 3
- Very bright retro - lighting

2. Range

Boiler type	MCA	45	65	90	115	
Useful output at 50/30°C P _n	kW	43	65	89.5	114	
Efficiency	100% P _n at average temp. 70°C	%	97.2	98.3	97.9	96.6
at ...% output	100 % P _n at return temp. 30°C	%	102.9	104.6	104.1	102.5
and ...°C water temp.	30 % P _n at return temp. 30°C	%	107.7	108.9	108.1	107.1
Nominal water flow at P _n , Δt = 20 K	m ³ /h	1.72	2.62	3.62	4.60	
Auxiliary electrical power at P _n /P _{min} (without circul. pump)	W	68/18	88/23	125/20	199/45	
Min./max. useful output at 50/30°C	kW	8.9-43	13.3-65.0	15.8-89.5	18.4-114	
Min./max. useful output at 80/60°C	kW	8-40	12-61	14.1-84.2	16.6-107	
Min./max. flue gas mass flow rate	kg/h	14/69	21/104	28/138	36/178	
Pressure available at the boiler outlet	Pa	150	100	160	220	
Water content	l	5.5	6.5	7.5	7.5	
Min. necessary water flow (*)	m ³ /h	0.4	0.4	0.4	0.4	
Water resistance at Δt = 20 K	mbar	90	130	140	250	
Gas flow	natural gas H	m ³ /h	4.4	6.6	9.1	11.7
(15°C-1013 mbar)	propane	m ³ /h	1.7	2.5	3.5	4.7
Net weight	kg	53	60	68	69	

(*) in the event of operating > 75°C, the minimum flow is calculated Δt = 45 K

The different models

- **MCA 45** 8 to 43 kW
- **MCA 65** 12 to 65 kW
- **MCA 90** 14 to 90 kW
- **MCA 115** 16 to 114 kW

(Output given at 40/30°C)

**Air / Flue gas connection and
hydraulic connection kit in OPTION**



Innovens Pro MCA 45-115

Main evolutions in comparison with MC 45 -115:

Modern aesthetics (dito Innovens MCA)

Standardisation of the casing:

- Identical dimensions on all the range
h x w x d: 750 x 500 x 500 mm
- Flow and return on the whole range
1¼" out.
- Reduction of the weight:

Model	MC	MCA
45	57 kg	53 kg
65	64 kg	60 kg
90	72 kg	68 kg
115	74 kg	69 kg

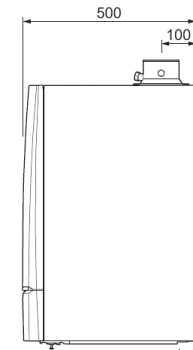
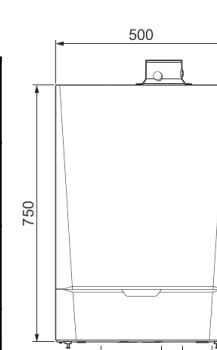
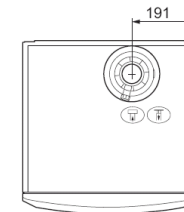

Innovens Pro MCA 45-115

Innovens Pro MCA 45-115

- Main evolutions in comparison with MC 45 -115:
Lighting by LED



DESCRIPTION

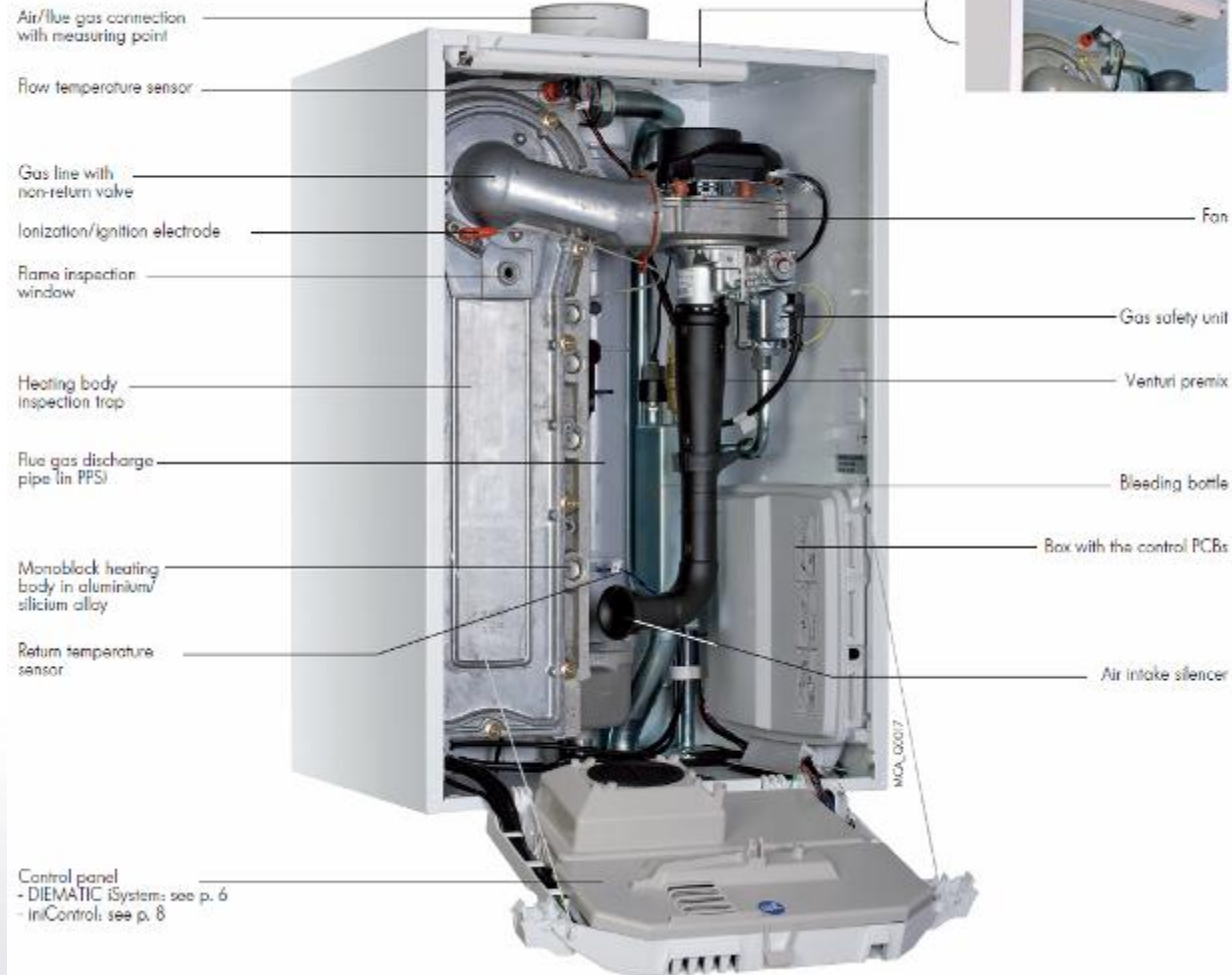

Innovens Pro MCA 45-115

- **Main evolutions in comparison with MC 45 -115:**
 - Lid anti-return on the gas circuit
 - Answers the requirements of cascade installations
And forced flue chimney pipes



Innovens Pro MCA 45-115



Main evolutions in comparison with MC 45 -115:

- Choice of one of the two control panels:
 1. iniControl : is used mainly in installations (wether in cascade or not) with external control cabinet for controlling all secondary circuits though the 0-10V contact. The panel can also be used alone to control a direct circuit + 1 DHW circuit through an outside sensor.
 2. iSystem: control panel in wich the control system is open to all installation configurations, including the most complex.



Boiler delivered without *Display*

Choice of control panel

INSTALLATION WITH A SINGLE BOILER

2 types of control panel are possible:



iniControl

- for installations with control cabinet in 0-10 V in the boiler room
- for controlling a single direct circuit without hourly programming

Option:

outside sensor

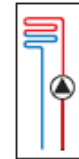

MCA...



DIEMATIC-iSystem

- for controlling a circuit:

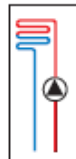

direct

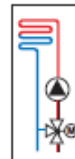

valve

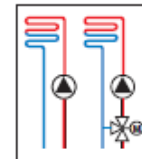

direct + 1 valve

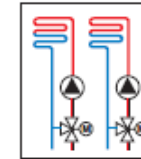

2 x valve

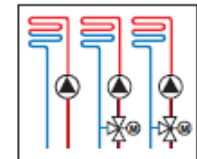

direct + 2 x with valve

Options:

as standard

1 outlet sensor
AD 199



1 outlet sensor
AD 199



1 outlet sensor
AD 199
+ 1 PCB
+ sensor AD 249



1 outlet sensor AD 199
+ 1 PCB
+ sensor AD 249



Choice of control panel

INSTALLATION WITH BOILER IN CASCADE (2 TO 10 BOILERS)

With control panel iniControl :



iniControl

All of the boilers (as many as 10) will be connected using the 0-10V contact to a control cabinet in the boiler room, which will manage all secondary circuits

Choice of control panel

INSTALLATION WITH BOILER IN CASCADE (2 TO 10 BOILERS)

- for controlling a circuit:

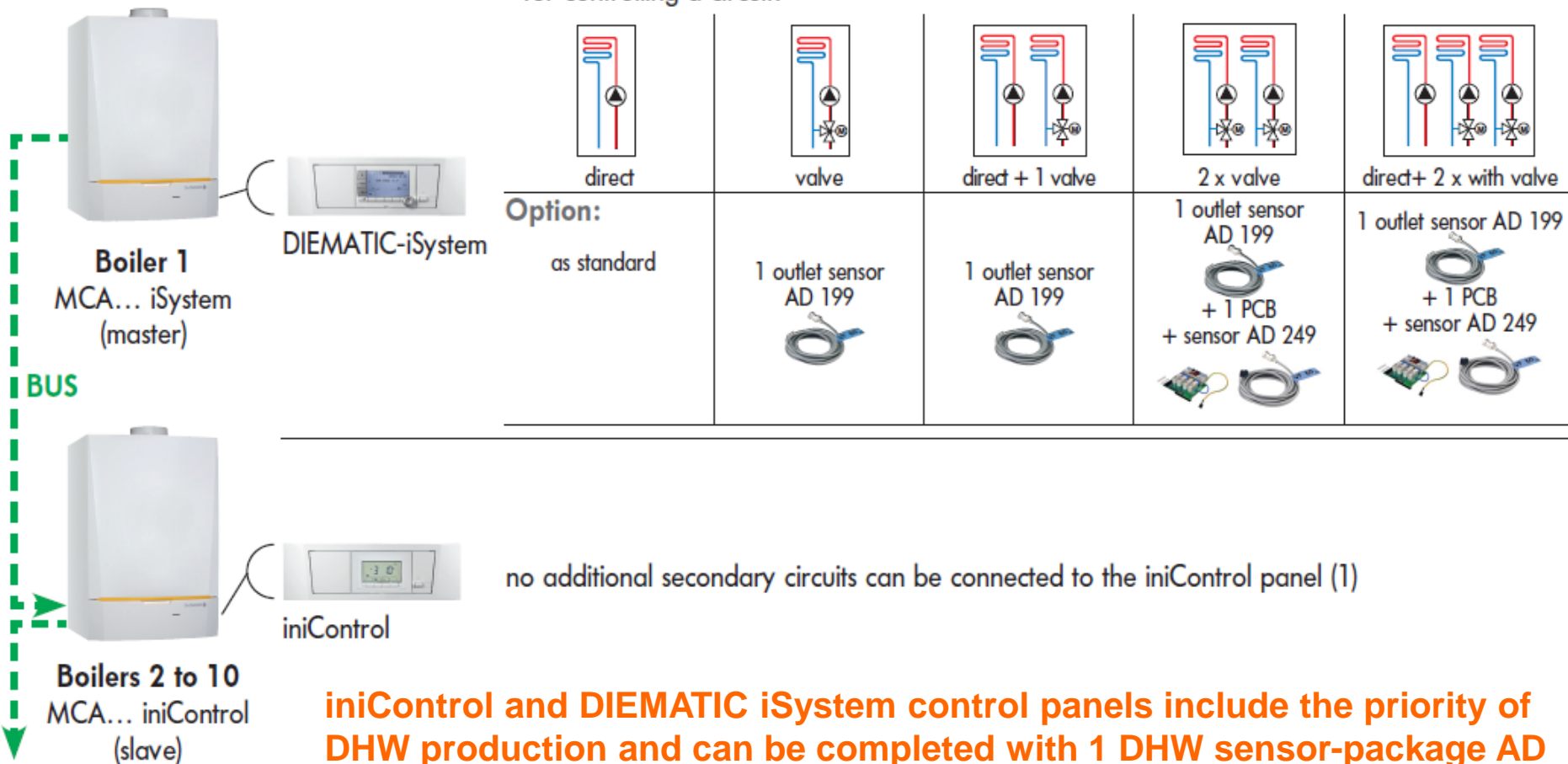

no additional secondary circuits can be connected to the iniControl panel (1)

iniControl and DIEMATIC iSystem control panels include the priority of DHW production and can be completed with 1 DHW sensor-package AD 212 to control an DHW tank.

Innovens Pro MCA 45-115



- 1st control panel level : **iniControl**

– Single boiler : 2 solutions

– Cascade of boiler

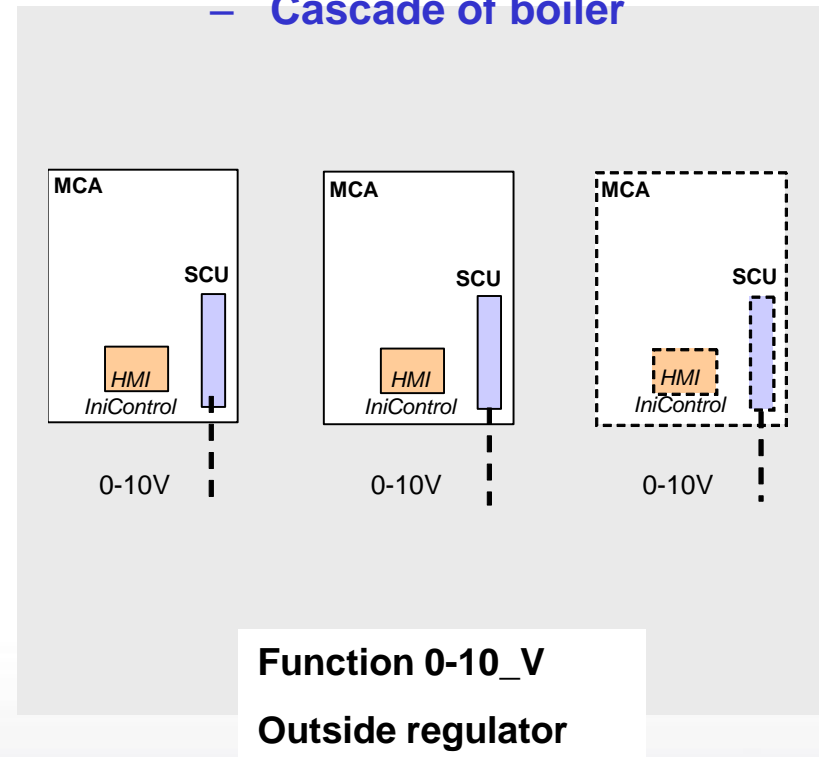
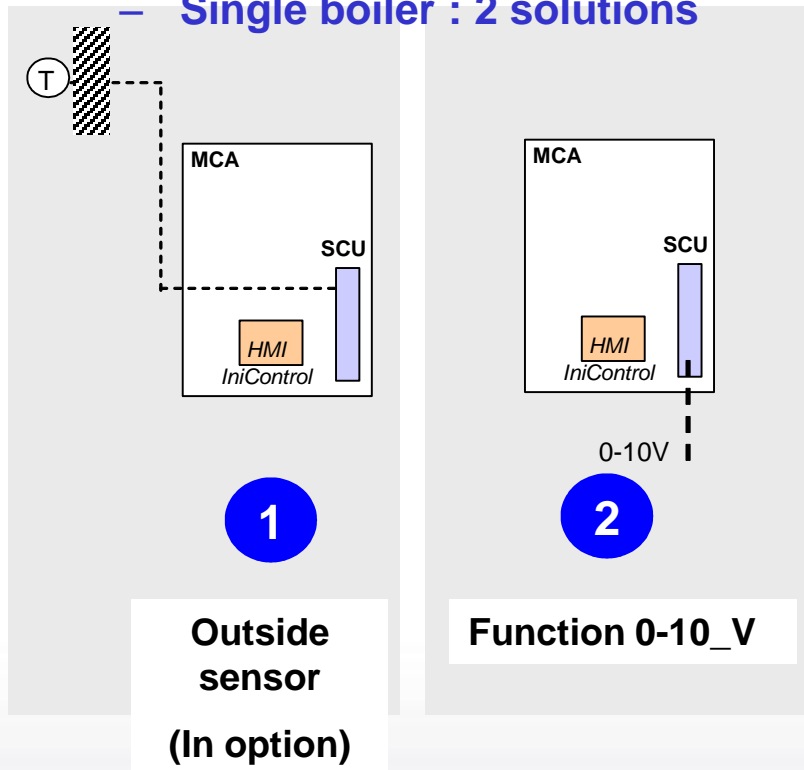

Innovens Pro MCA 45-115

- 2nd control panel level: **Diematic iSystem**



- **Single boiler**

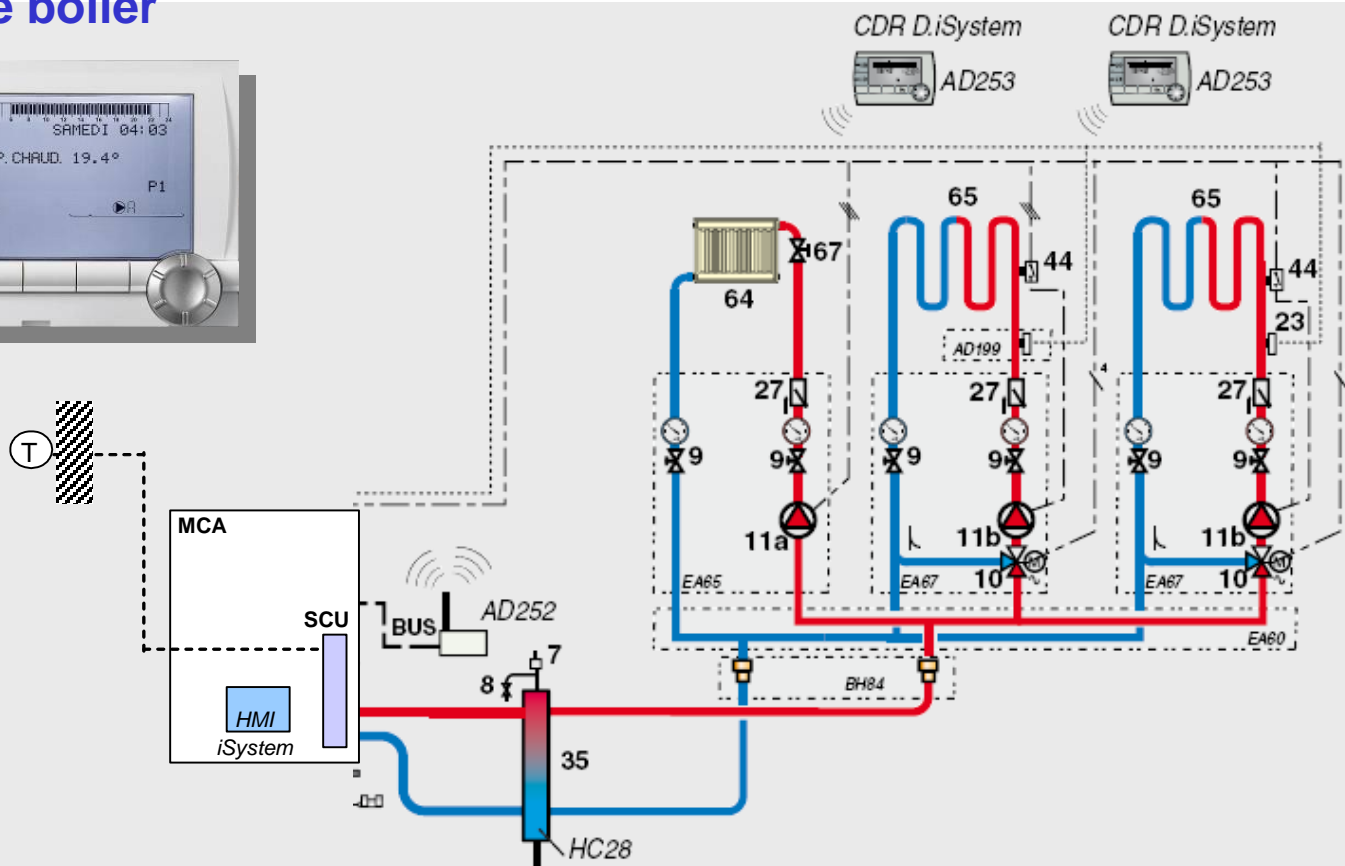

Innovens Pro MCA 45-115

- 2nd control panel level: **Diematic iSystem**

– Boilers in cascade

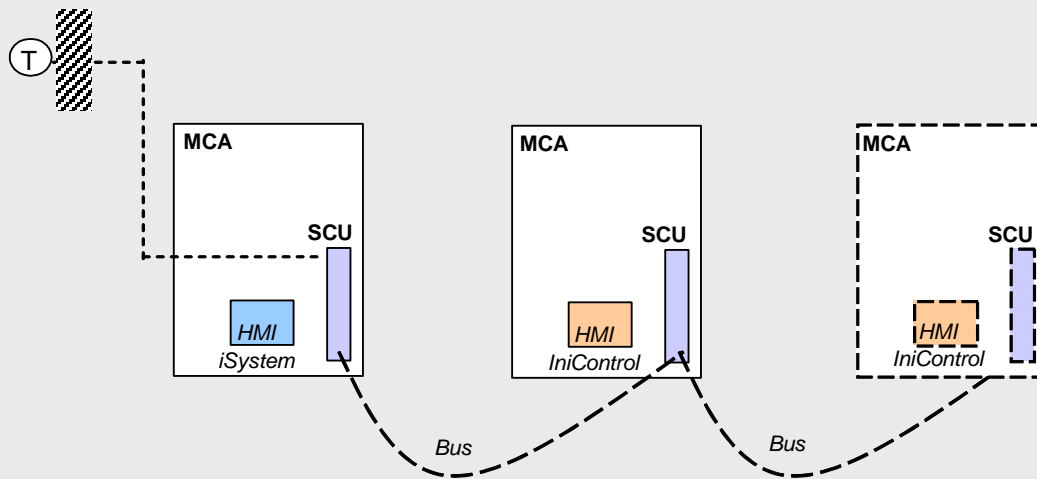

iSystem



iniControl





iniControl

De Dietrich 

Innovens Pro MCA 45-115

- Main evolutions in comparison with MC 45 -115:
- Commercial specifications:



Tableau de commande	Modèle INNOVENS PRO	Plage de puissance (kW)		
		à 50/30 °C	à 80/60 °C	
DIEMATIC iSystem 	MCA_Q0010	MCA 45 iSystem	8,9 à 43,0	8,0 à 40,0
		MCA 65 iSystem	13,3 à 65,0	12,0 à 61,0
		MCA 90 iSystem	15,8 à 89,5	14,1 à 84,2
		MCA 115 iSystem	18,4 à 114,0	16,6 à 107,0
iniControl 	MCA_Q0019	MCA 45 iniControl	8,9 à 43,0	8,0 à 40,0
		MCA 65 iniControl	13,3 à 65,0	12,0 à 61,0
		MCA 90 iniControl	15,8 à 89,5	14,1 à 84,2
		MCA 115 iniControl	18,4 à 114,0	16,6 à 107,0

Innovens Pro MCA 45-115

- Main evolutions in comparison with MC 45 -115:
 - All the models are adaptable to the propane
 - No more kit necessary for the MCA 115
 - By setting of the CO₂ for MCA 45, 65 et 115
 - For MCA 90 Replacement of the diaphragm (factory setting)

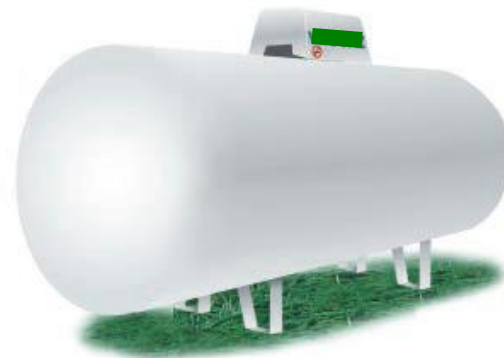

Innovens Pro MCA 45-115

Main evolutions in comparison with MC 45 -115:



- Hydraulic connection kit

- Front cover ABS (no combination with hydraulic connection kit)

- Insulation casing

De Dietrich 

Innovens Pro MCA 45-115

- Cascade system
- Combinations remain Identical:
 - Complete systems of cascade

LW Wall-hung alignment
LV Floor-standing alignment
RG Back to back assembly

- Collector and hydraulic connections remain identical

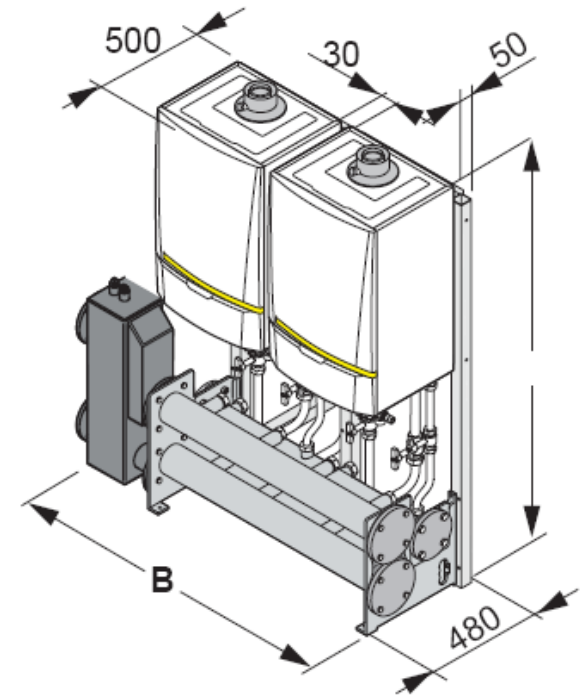

3. Options

The iSystem options

Outlet sensor
after 3-way
valve
Package
AD199



Flue gas
thermostat
Package- HR
43



voice remote monitoring
module- Package AD 152



PCB + sensor
for a mixing
valve - Package
AD 249



System Sensor-
Package AD 250



Domestic hot
water sensor
Package AD 212



Les options iSystem

A simplified remote control with room sensor- Package FM 52



**Room Sensor
- Package AD 244**

Interactive remote control CDI D. iSystem

- Package: AD 254
interactive radio remote control module CDR D. iSystem (Without radio transmitter)- Package AD 253
Boiler radio module (Transmitter/receiver)
- Package: AD 252



**Outside Sensor radio -
Package AD 251**
**Boiler radio module
(radio transmitter)
Package AD 252**



The iniControl options

- **Cable {BUS}-
Package AD 134**



- **Outside sensor
Package AD 122**



Boiler options

- **Hydraulic connection kit in option**
 - This kit includes:
 - Return/flow tap
 - Gas valve
 - Safety valve
 - Connection for expansion vessel
 - Filling valve
- **1 Kits**
 - Diameter 1“1/4 (HC 139)



Boiler options

Hydraulic connection kit insulation -

Package HC 252

Hydraulic connection kit rear insulation

- Package HC 243

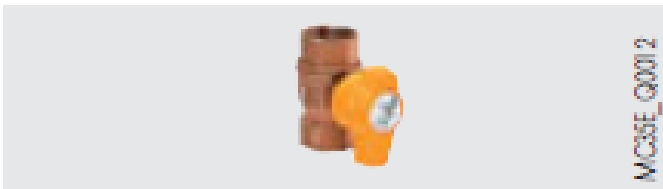
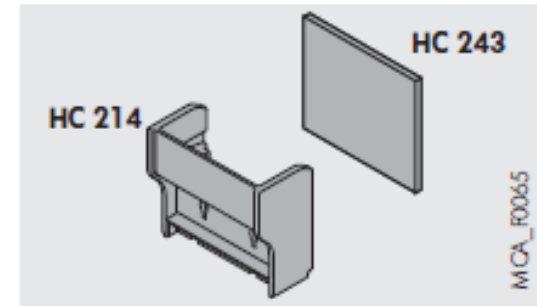

Right gas valve RP 3/4
- Package HC 158

Pipe cover
- Package HC 242

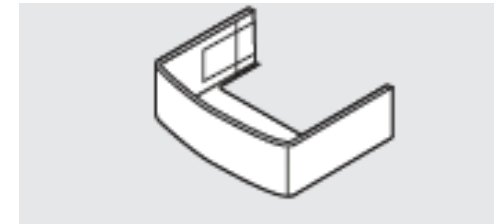

Fume thermostat
- Package HR 43

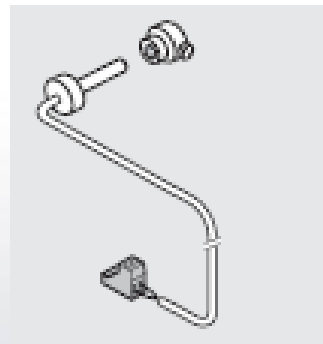

Boiler options

- 3 speed pump(fitted on the boiler H = 130 mm)
 UPS 25-60 for MCA PRO 45 (HC 141)
 UPS 25-70 for MCA PRO 65 (HC 143)
 UPS 25-80 for MCA PRO 90 (HC 145)

(delivered with 2 Pipe unions 1"1/2-1")



Specifications of the pump UPS 25-60 130

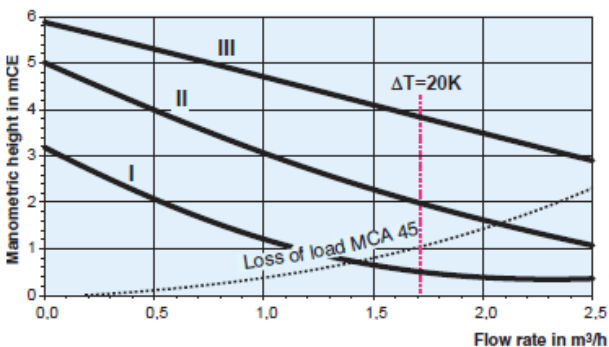

Specifications of the pump UPS 25-70 130

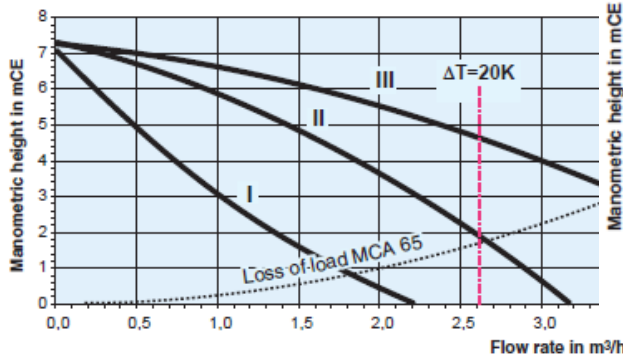

Specifications of the pump UPS 25-80 130

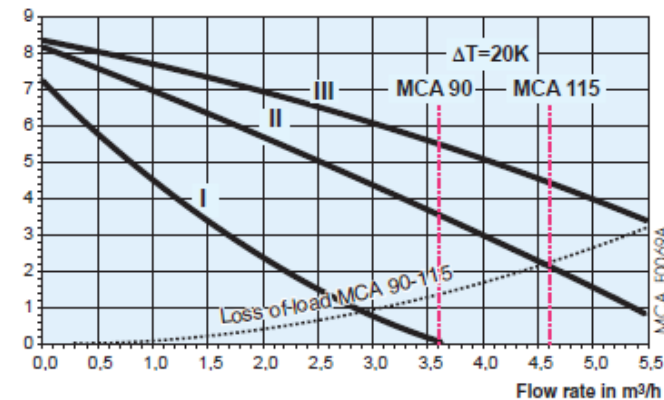

Boiler options

- Primary pump for MCA PRO 45, 65, 90 and 115 used as injection pump (cascade) (fitted outside the boiler, height 180mm)

HC 147



HC 142 electronic modulating **class A**

Specifications of the pump UPS 25-55 180

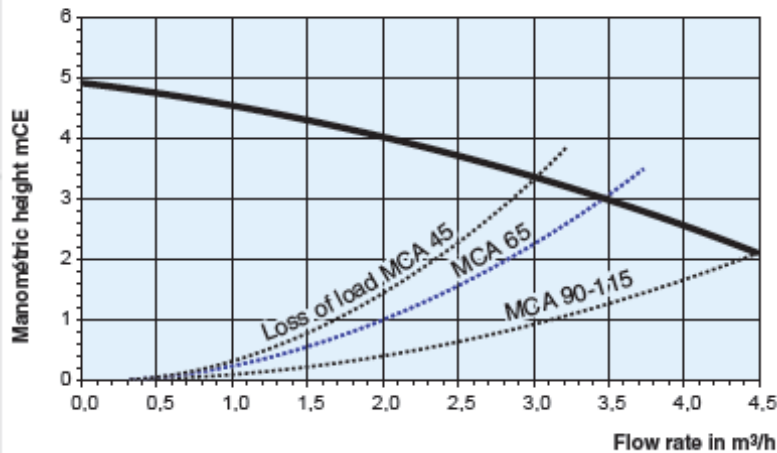

Specifications of the pump ALPHA 2 L 25-60 130

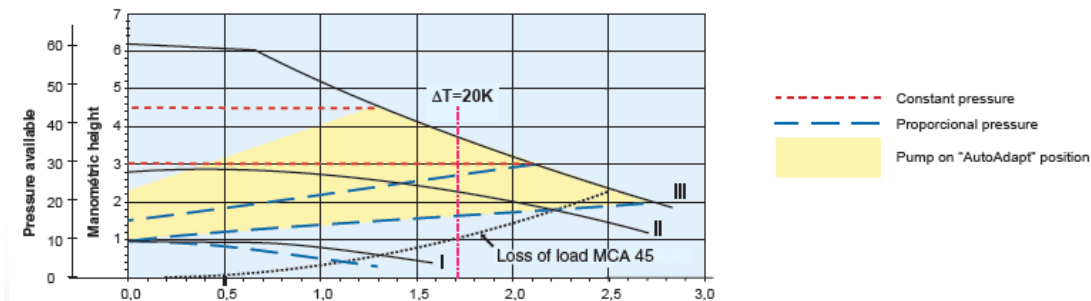

Boiler options

- Heating / DHW inversion valve: Package HC 135
- 3 way valve with motor 1" : Package HC 15

Hydraulic connection kit : MCA PRO 45, 65, 90 and 115 /DHW tank BP/BL..., UNO/2, DUO/2 or TRIO - Package EA 121

	BP/BL...	UNO/2, DUO/2, TRIO
H mini	1080 maxi	800 mini

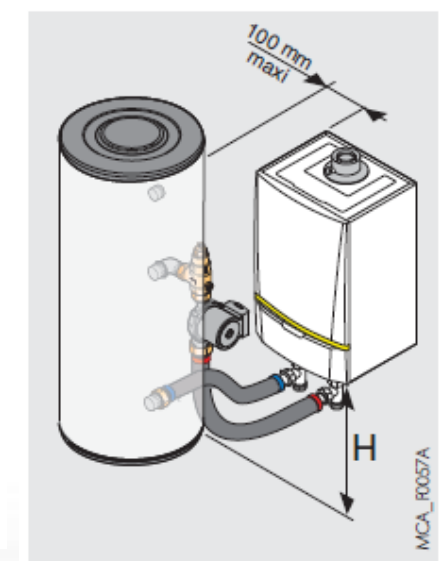

Boiler options

De Dietrich
MCA 45
MCA 65
MCA 90
MCA 115

DTG130- 45
DTG130- 65
DTG130- 90
DTG130- 115

C230-85
C230-130
C230-170
C230-210

GV45 60/60	GV46 80/60	GV47 120/80
max. 3,0 m3/h	max. 4,5 m3/h	max. 8,0 m3/h
OK	OK	
OK	OK	
	OK	"OK"
	OK	OK
OK	OK	
OK	OK	
	OK	"OK"
	OK	OK
	OK	OK
	OK	OK
	OK	OK



The 3 types of decoupling cylinders fitted with a PPE isolating shell are including wall brackets, 1 x blind cap 1/2", 1 x air vent 1/2" and 1 x 1/2" drain valve.

Boiler options

The condensate neutralisation tank – DU13/14/15

Granulate 10 kg

- Neutralisation box for the condensate water : Package HC 33
- Wall bracket for neutralisation tank HC 33: Package HC 34



Boiler options

- **Cleaning tools heat exchanger:**
- **Package** HC 246 for MCA PRO 45 and MCA PRO 65
- **Package** HC 247 for MCA PRO 90 and MCA PRO115

- **Bi-flow adapter** Ø 80/125 mm to 2 x 80 mm : **Package** DY 906
- **Bi-flow adapter** Ø 100/150 mm to 2 x 100 mm : **Package** Colis DY 907



Innovens cascade

Cascade system enabling:

- More than **1600** combinations from 2 to 10 boilers for installations between 80kW and 1070kW
 - **From 80 to 428 kW = DN 65**
 - **From 428 to 1070 kW = DN 100**
- 3 versions are available
 - For wall-hung alignment (7 maxi)
 - For floor standing alignment (7 maxi)
 - For back to back assembly (10 maxi; 5+5)
- Boiler connection insulation kits available



Innovens cascade

A « cascade determination » tool is at your disposal on our internet site.

- **49** solutions of cascade in DN 65 from 80kW to 428kW (80-60°) combinations of 2 to 4 boilers and 3 types of assembling

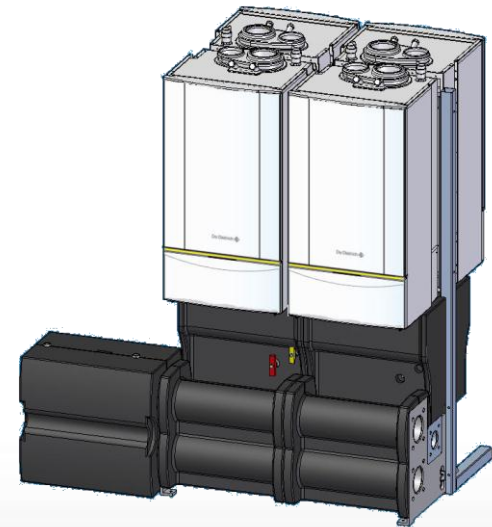
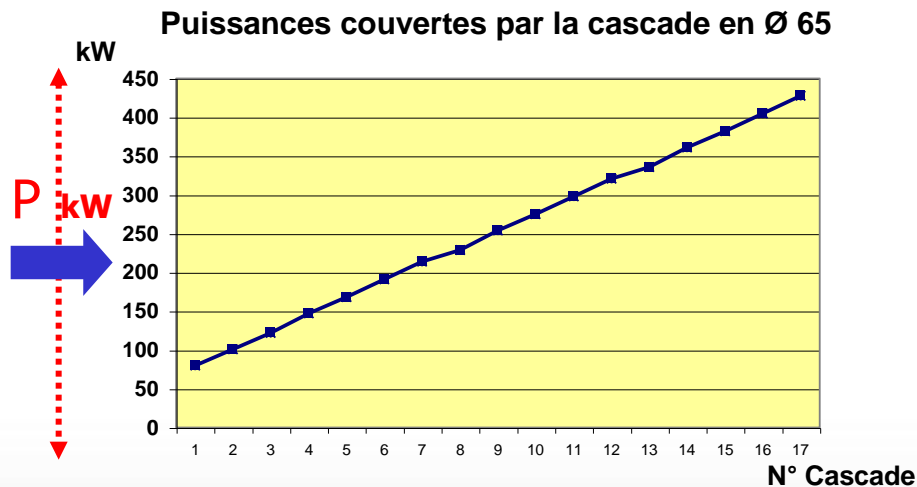

Cascade with power output > 428 kW (80/60°) on demand

Innovens cascade

WALL-HUNG ALIGNMENT OF THE BOILERS "LW"

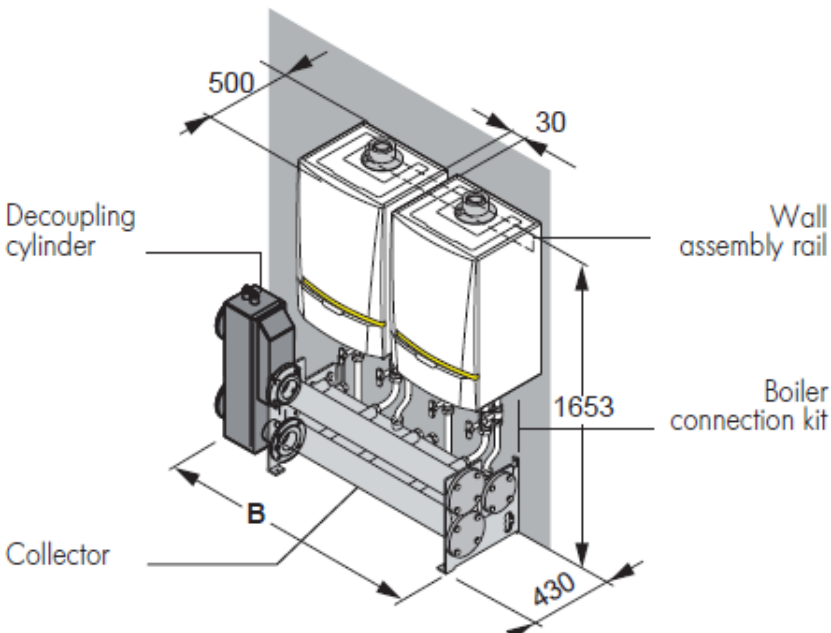

Num. of boilers	Output (80/60°C) kW	Boiler type MCA				B mm	Water flow $\Delta t = 20K$ m ³ /h	Description
		45	65	90	115			
2	080	2	0	0	0	1337	3.43	LW.0080kW.2000
	122	0	2	0	0	1337	5.23	LW.0122kW.0200
	168	0	0	2	0	1337	7.20	LW.0168kW.0020
	214	0	0	0	2	1337	9.17	LW.0214kW.0002
3	120	3	0	0	0	1867	5.14	LW.0120kW.3000
	183	0	3	0	0	1867	7.84	LW.0183kW.0300
	252	0	0	3	0	1867	10.80	LW.0252kW.0030
	321	0	0	0	3	1867	13.76	LW.0321kW.0003
4	160	4	0	0	0	2397	6.86	LW.0160kW.4000
	244	0	4	0	0	2397	10.46	LW.0244kW.0400
	336	0	0	4	0	2397	14.40	LW.0336kW.0040
	428 (1)	0	0	0	4	2739	18.34	LW.0428kW.0004

Innovens cascade

FLOOR-STANDING ALIGNMENT OF THE BOILERS "LV"

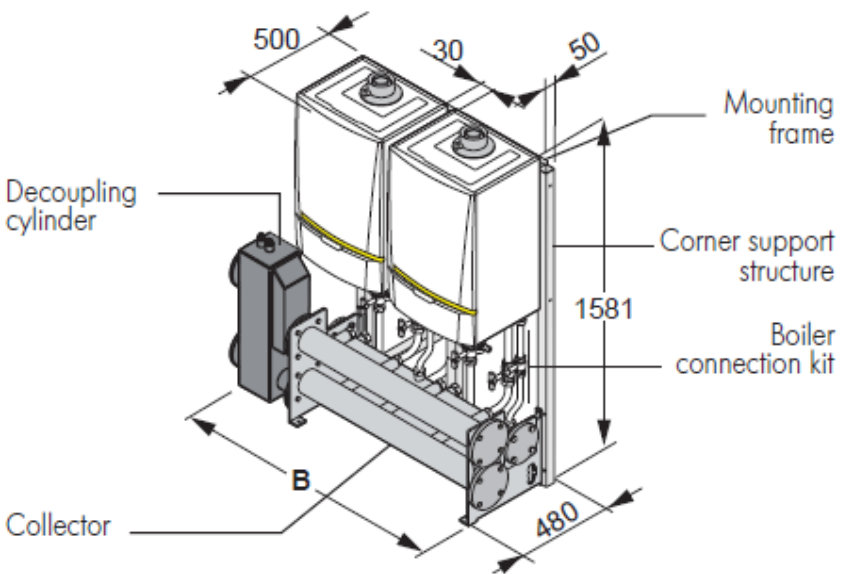

2	080	2	0	0	0	1362	3.43	LV.0080kW.2000
	122	0	2	0	0	1362	5.23	LV.0122kW.0200
	168	0	0	2	0	1362	7.20	LV.0168kW.0020
	214	0	0	0	2	1362	9.17	LV.0214kW.0002
3	120	3	0	0	0	1892	5.14	LV.0120kW.3000
	183	0	3	0	0	1892	7.84	LV.0183kW.0300
	252	0	0	3	0	1892	10.80	LV.0252kW.0030
	321	0	0	0	3	1892	13.76	LV.0321kW.0003
4	160	4	0	0	0	2422	6.86	LV.0160kW.4000
	244	0	4	0	0	2422	10.46	LV.0244kW.0400
	336	0	0	4	0	2422	14.40	LV.0336kW.0040
	428 (1)	0	0	0	4	2739	18.34	LV.0428kW.0004

Innovens cascade

BACK TO BACK ASSEMBLY OF THE BOILERS "RG"

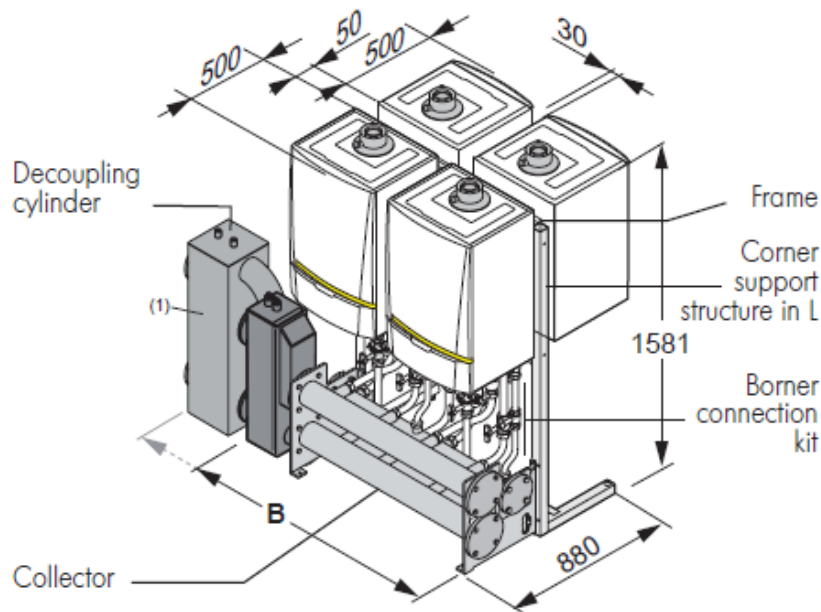

3	120	3	0	0	0	1362	5.14	RG.0120kW.3000
	183	0	3	0	0	1362	7.84	RG.0183kW.0300
	252	0	0	3	0	1362	10.80	RG.0252kW.0030
	321	0	0	0	3	1362	13.76	RG.0321kW.0003
4	160	4	0	0	0	1362	6.86	RG.0160kW.4000
	244	0	4	0	0	1362	10.46	RG.0244kW.0400
	336	0	0	4	0	1362	14.40	RG.0336kW.0040
	428 (1)	0	0	0	4	1679	18.34	RG.0428kW.0004

(1) With large cylinder

Caption: Description LW 0080kW/2000

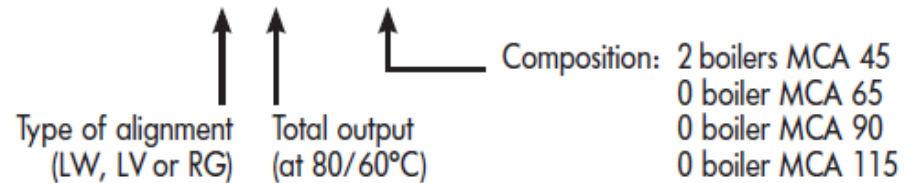

Innovens cascade

Easy mounting

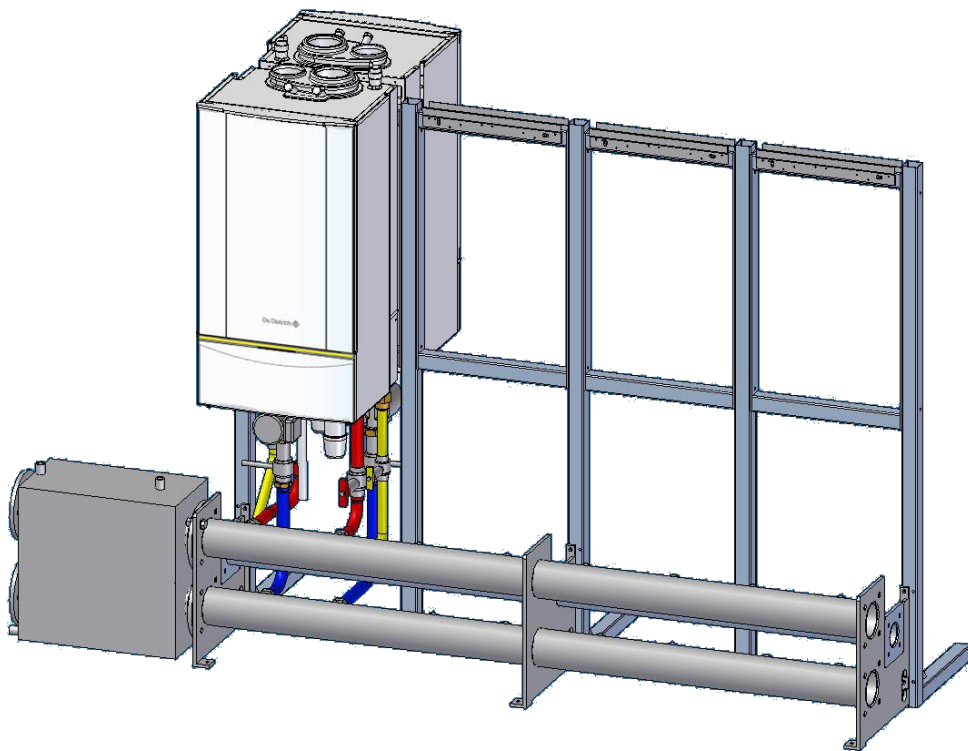

- Grande stabilité en pose libre
- Pieds réglables (en option)
- Accessoires d'assemblage (visseries) livrés
- Outillages de montage réduits



13 - 19 - 24 - 46 - 50 - 55

Innovens cascade

Basic composition of cascade

- 1 Kit de raccordement Av
- 2 Kit de raccordement Ar
- 3 Pompe
- 4 Sonde de départ + doigt de gant
- Câble bus de liaison entre chaudières

Options:

- 6 Isolation collecteur (1/ raccordement)
- 7 Isolation raccordement chaudière
- 8 Isolation bouteille de découplage
- 9 Isolation coude à 90°

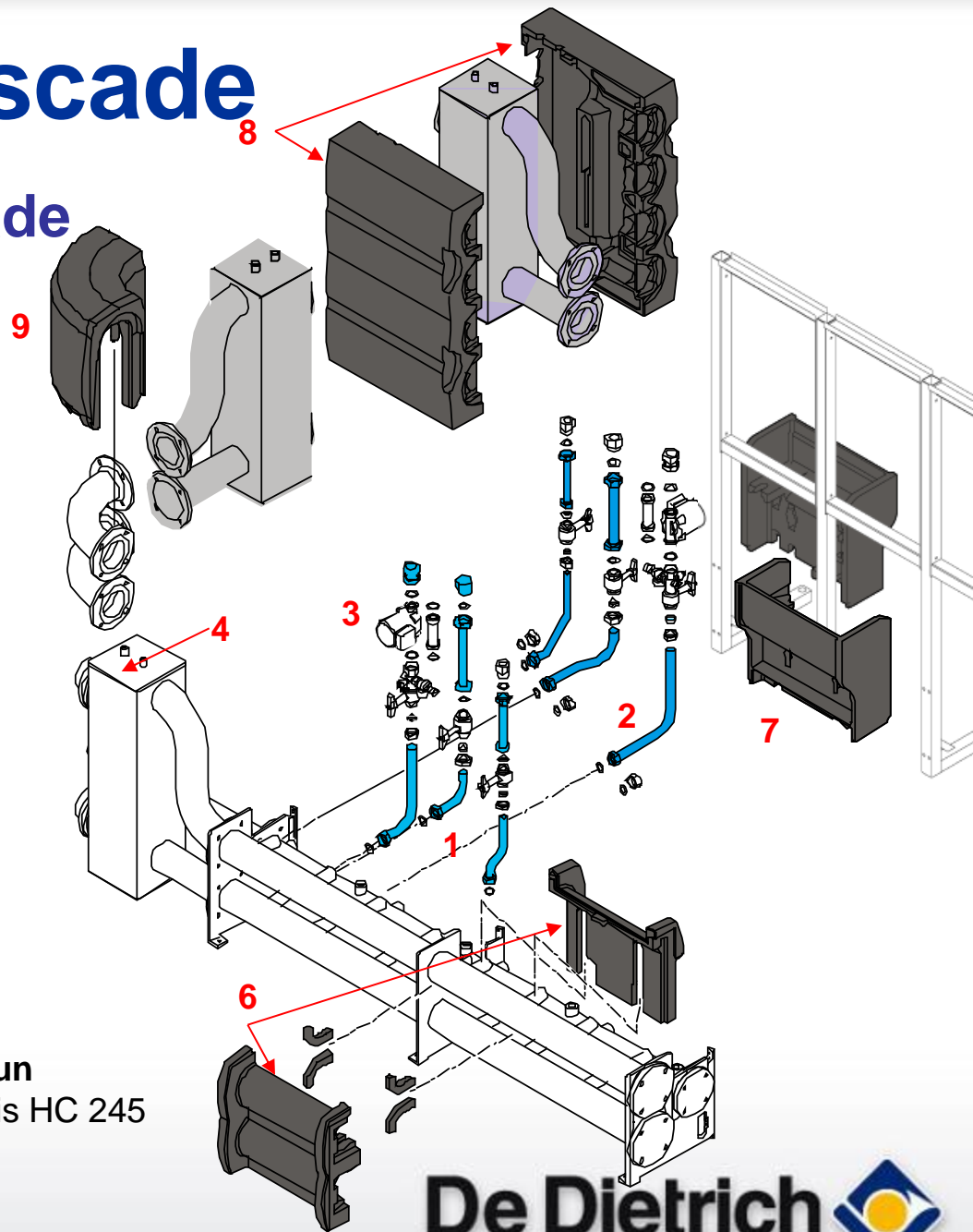

Rail de **montage MCA** sur un système **cascade MC** - Colis HC 245

MCA_F0065

De Dietrich 

Innovens cascade

Boiler connections

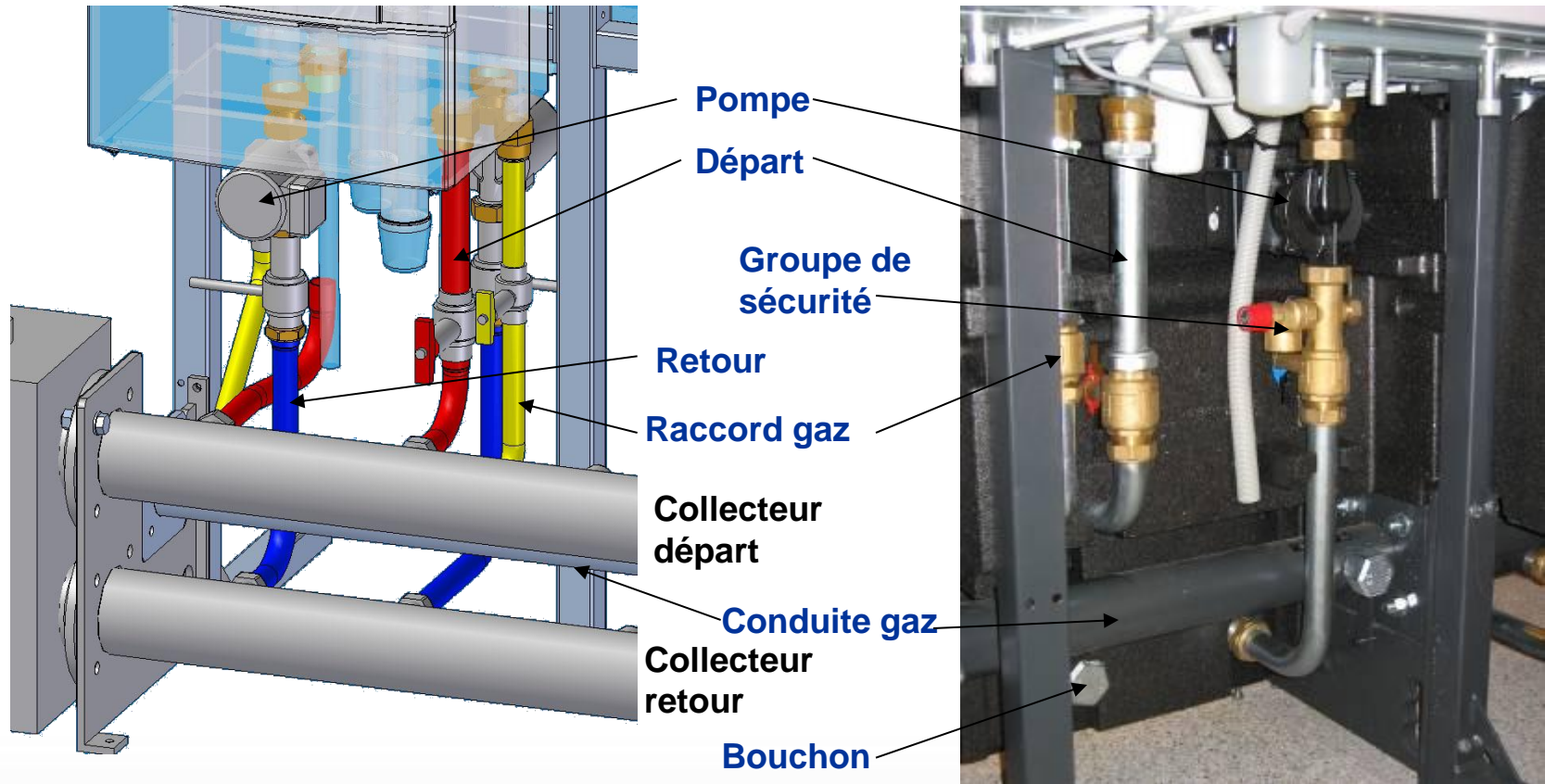

Innovens cascade

Gas filter with extension pipe

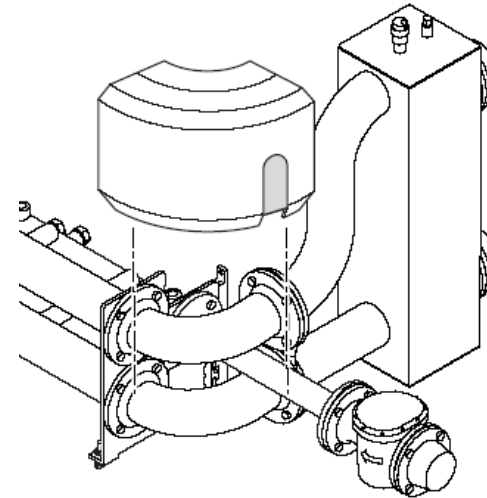
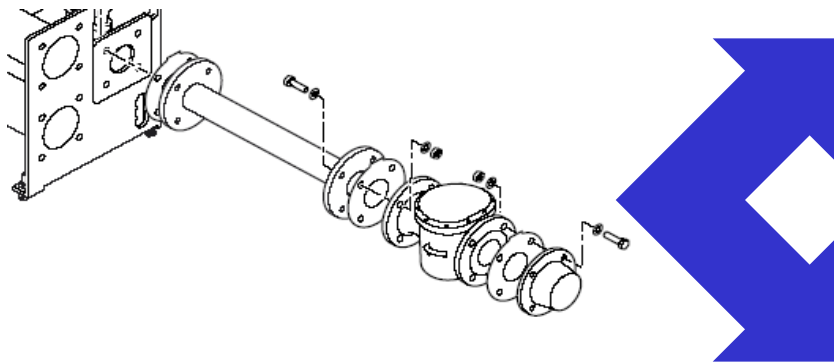

Elbow 90°

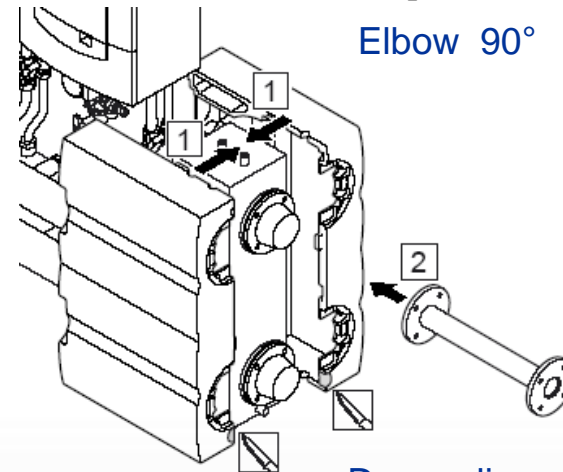

Decoupling cilinder with insulation

4.1 Air/Flue gas connection

Air/Flue gas connection

AIR/FLUE GAS CONNECTION

For the use of the air/flue gas connection pipes and the rules on installation, see details of the various configurations in the current product catalogue.

Classification

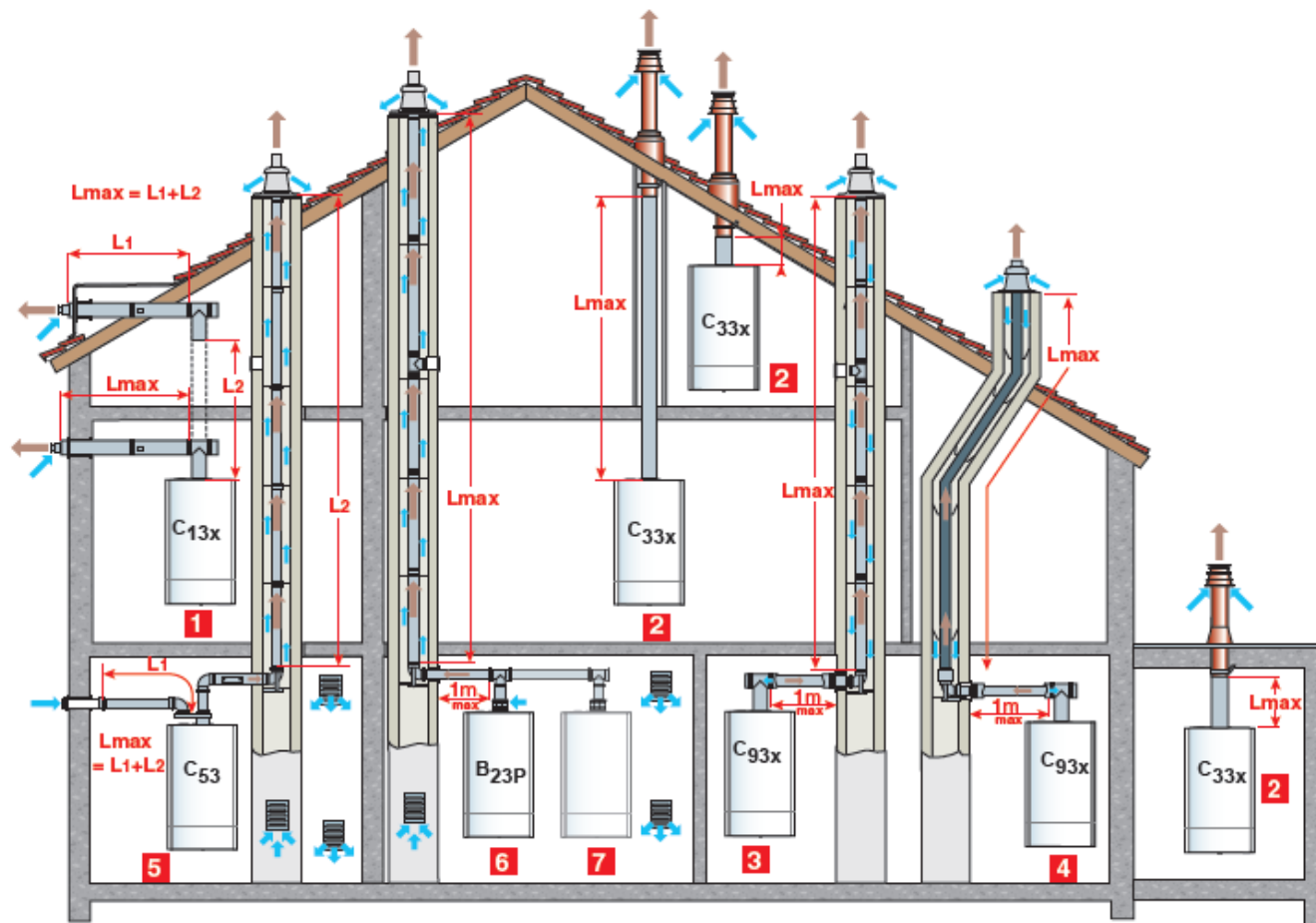

- 1 Configuration C_{13x}**: Air/flue gas connection by means of concentric pipes to a horizontal terminal (so-called forced flue)
- 2 Configuration C_{33x}**: Air/flue gas connection by means of concentric pipes to a vertical terminal (roof outlet) or
- 3 Configuration C_{93x} (formerly C_{33x})**: Air/flue gas connection using concentric pipes in the boiler room and single pipes in the chimney (combustive air with counter current in the chimney) or
- 4** Air/flue gas connection using concentric pipes in the boiler room and single "flex" pipes in the chimney (combustive air with counter current in the chimney)
- 5 Configuration C₅₃**: Separate air and flue gas connection using a bi-flow adapter and single pipes (combustive air taken from outside)
- 6 Configuration B_{23P}**: Connection to a chimney (combustive air taken from the boiler room)
- 7 Configuration B_{23P}**: For cascade installation

Type of air/flue gas connection			Lmax of the connecting pipes in m			
			MCA 45	MCA 65	MCA 90	MCA 115
Concentric pipes connected to a horizontal terminal (PPS)	C _{13x}	Ø 80/125 mm	16	-	-	-
		Ø 110/150 mm	-	9	8	5.9
Concentric pipes connected to a vertical terminal (PPS)	C _{33x}	Ø 80/125 mm	14.5	-	-	-
		Ø 110/150 mm	-	11.5	10	9.4
Pipes - concentric in the boiler room, - single in the chimney (combustive air with counter current) (PPS)	C _{93x}	Ø 80/125 mm Ø 80 mm	15			
		Ø 80/125 mm Ø 100 mm	25			
		Ø 110/150 mm Ø 110 mm	-	16	13.2	10
Pipes - concentric in the boiler room, - "flex" in the chimney (combustive air with counter current) (PPS)	C _{93x}	Ø 80/125 mm Ø 80 mm	12			
		Ø 110/150 mm Ø 110 mm	-	16.5	13.5	9.4
Bi-flow adapter and separate single air/flue gas pipes (combustive air taken from outside) (Alu)	C ₅₃	Ø 80/125 mm to 2x80 mm	20.5			
		Ø 100/150 mm to 2x100 mm	-	23	17.5	16
In the chimney (rigid or flex) (combustive air taken from the premises) (PPS)	B _{23P}	Ø 80 mm (rigid)	23.5			
		Ø 80 mm (flex)	21			
		Ø 110 mm (rigid)		40	40	40
		Ø 110 mm (flex)		29.5	24	17.5

⚠️ Max. height in the flue pipe (C_{93x} and B_{23P} configurations) from the support elbow to the outlet musn't exceed :

- 30 m for rigid PPS

- 25 m for flex PPS

In case of higher lengths, holding collars must be added by slices of 25 or 30 m.

Important:

We remind you on the next page of the rule on installation of terminals on sealed appliances (type C) with a total output ≥ 70 kW installed in a boiler room, which use gas fuels.

Innovens cascade

The flue/gas connections

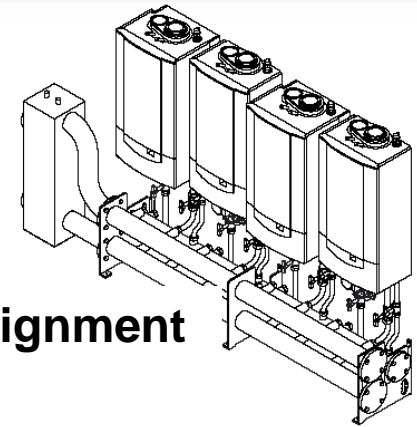

Cascade combinations with wall-hung and floor standing alignment

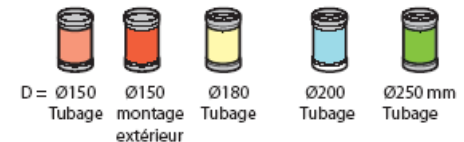
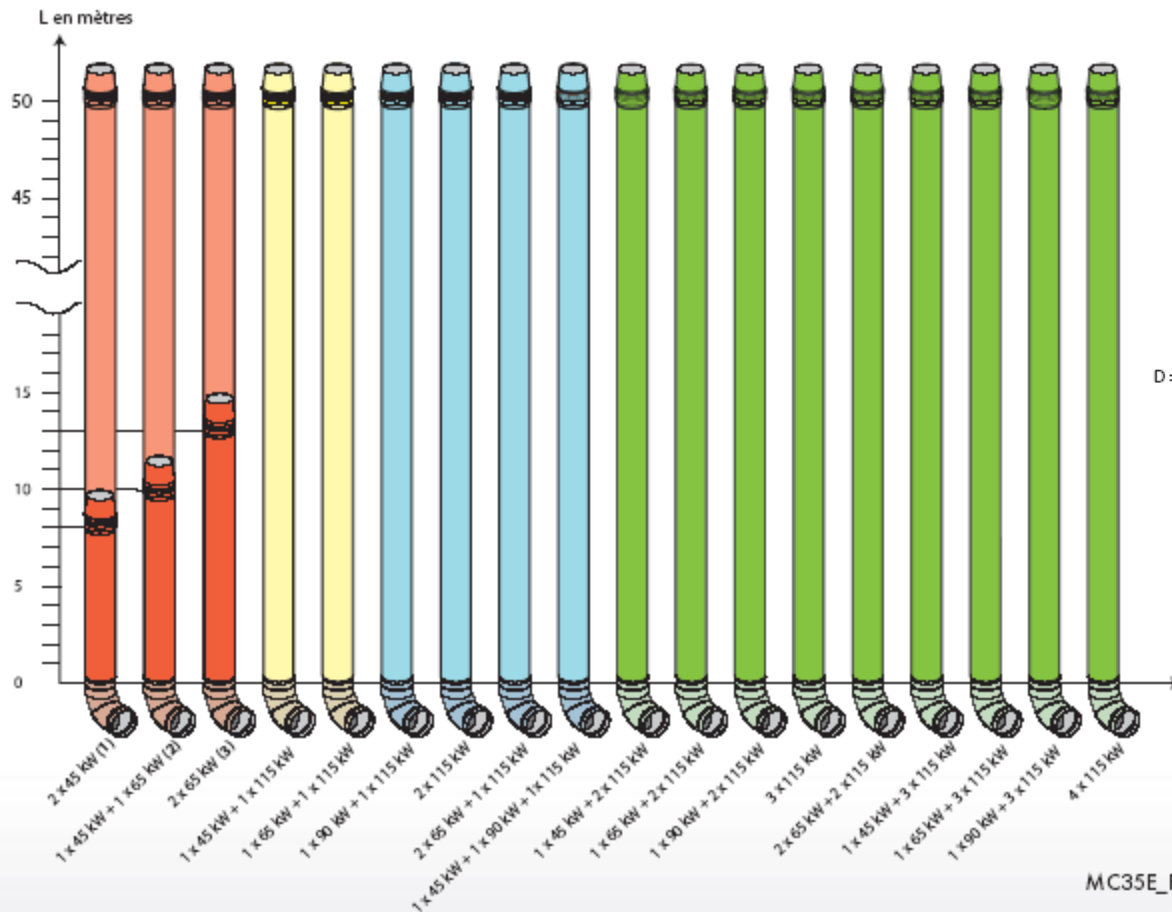

NB : dans le cas de conduits à l'extérieur, la hauteur maximum possible pour assurer le fonctionnement est :
 (1) : 7,90 m (2) : 10,20 m (3) : 13,10 m

MC35E_F0062



Concentric horizontal forced flue: C13

- Concentric horizontal forced flue

- Diameter 80/125 for MCA PRO 45

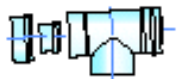

Colis DY15



Colis CX119

- Diameter 100/150 for MCA PRO 65 , MCA PRO 90 and MCA PRO 115



Colis CX11

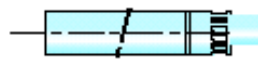

Colis CX100

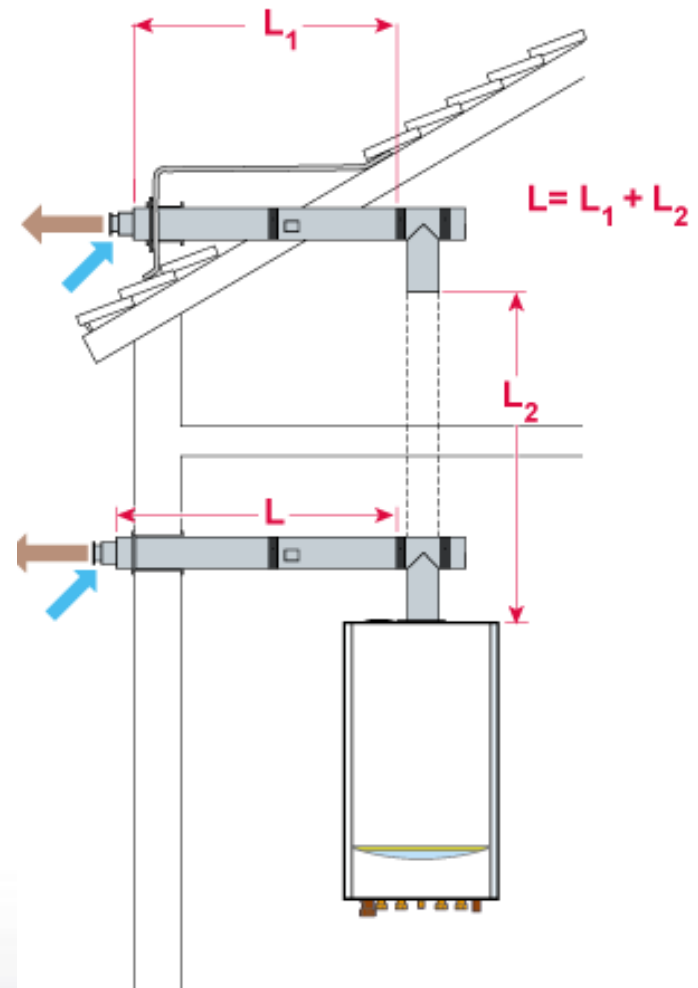

Concentric vertical forced flue: C33

- Vertical forced flue with concentric pipes
 - Diameter 80/125 for MCA PRO 45
 - Diameter 100/150 for MCA PRO 65, MCA PRO 90 and MCA PRO 115

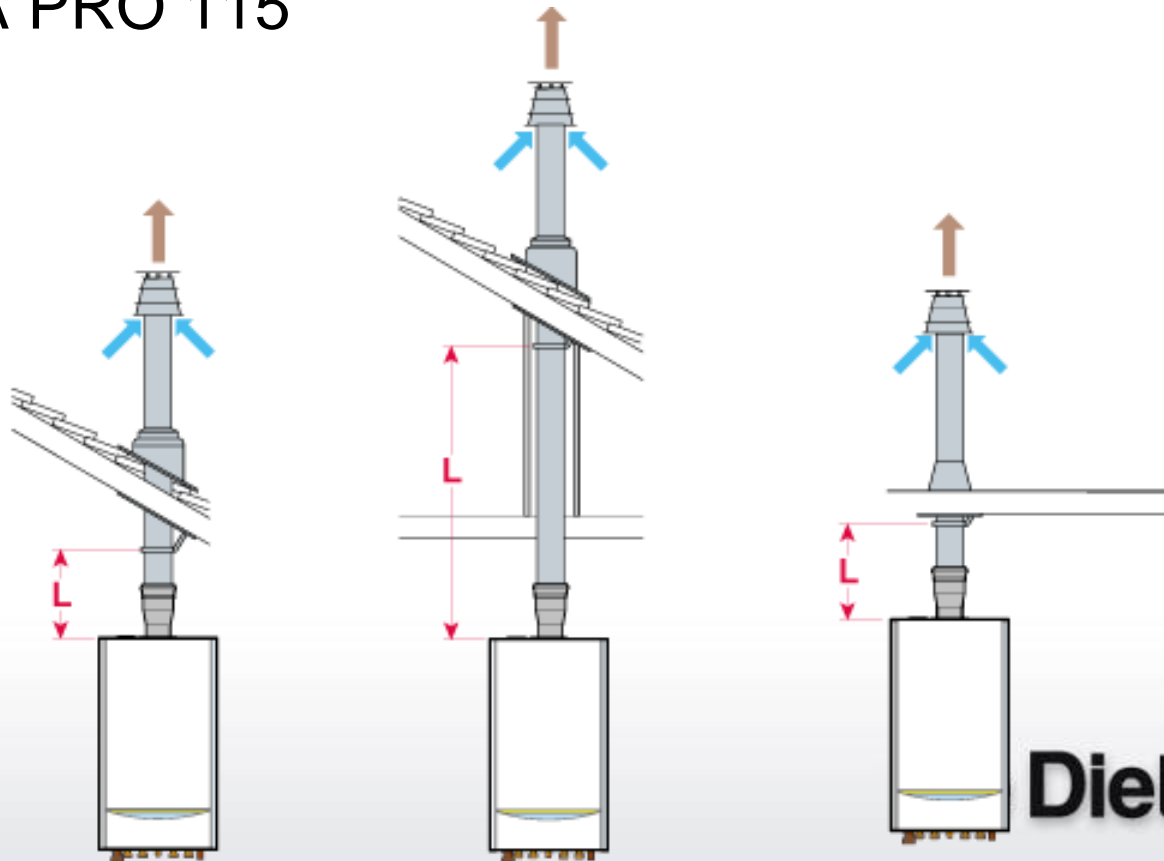

Vertical pipe in chimney (C93) in Alu/Alu rigid for MCA PRO 45

Configuration subjected to technical opinion
(N°: 14/04-867)

- Concentric pipes Alu/Alu in the boiler room
- Single pipes in the chimney

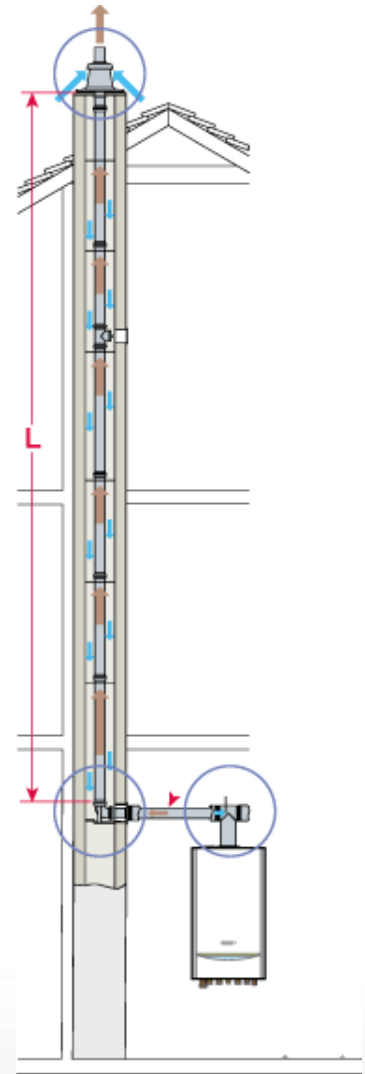

Single flue gas pipe in chimney and combustive air in counter-current (C93) in Alu/PPS and flexible PPS

Configuration subjected to technical opinion
(N°: 14/05-959)

- Concentric pipe Alu/PPS in boiler room
- Single flex pipe in chimney

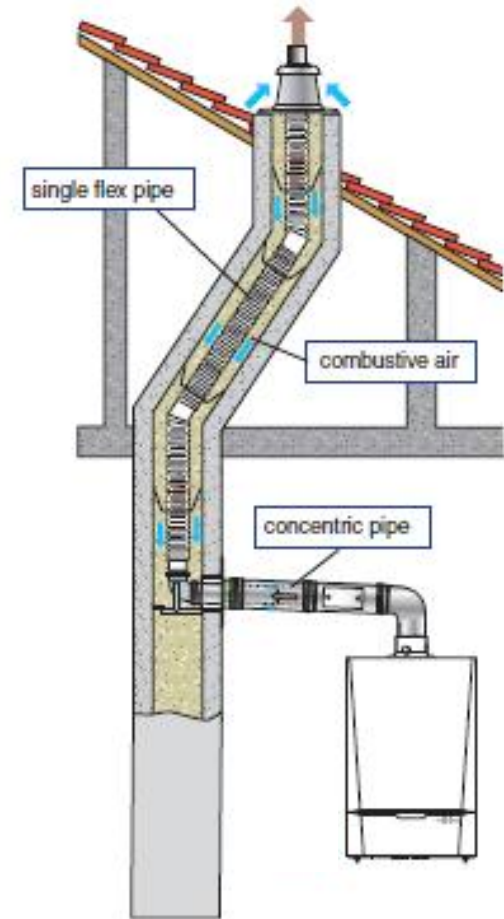

Bi-flow connection (C53)

Configuration subjected
to technical opinion
(N°: 14/04-867)

- Required to ventilate the boiler room
- Connection with single pipe in Alu

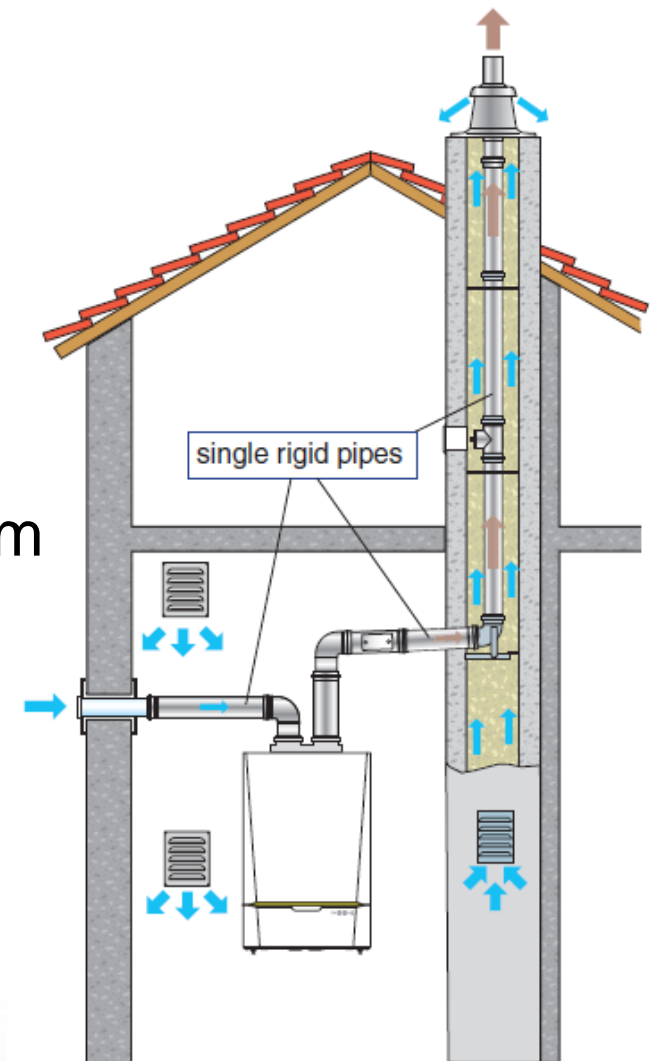

Chimney connection (B23P) en conduit PPS rigide ou flexible PPS

Configuration subjected to technical opinion (N°: 14/05-959)

- Combustive air taken in boiler room
- Ventilated boiler room
- Connection boiler/chimney in rigid PPS pipe
- Single pipes in the chimney in PPS rigid or flex pipe

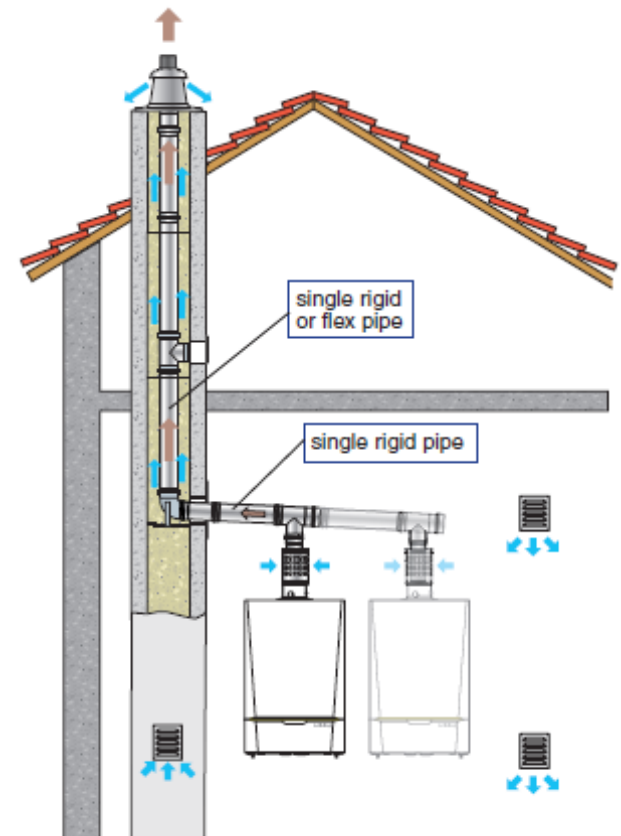

Condensates recuperator

The recuperator must be positioned on the boiler flue gas outlet at the base of the vertical section. A flow pipe must be connected to it. The flow of condensates should be into a waste water conduit.

The flow pipe must be installed so as to form a siphon, which will provide the tightness of the combustion products discharge pipe. The manometric height of the siphon must be equal to at least 50 mm. Fill the siphon with water after assembly (before first commissioning).

Pack

DY 916

Ø 80/125

DY 917

Ø 110

DY 918

Ø 110/150

DY 919

Ø 80

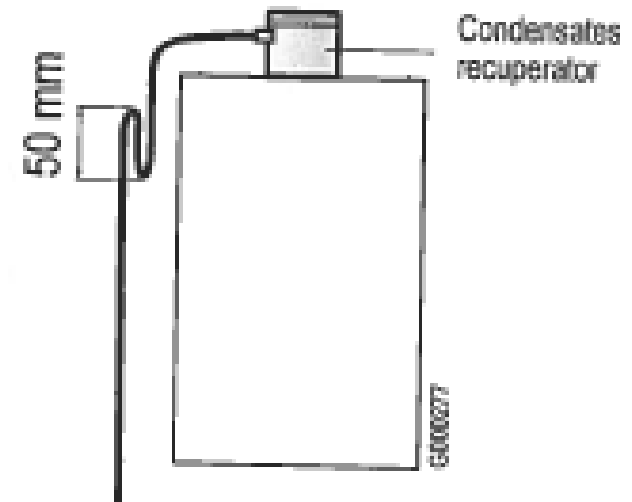

4.2 Principle and electronics

The electronic architecture

- **SU : Safety unit**
- **PSU: Parameter Storage Unit (for PCU and SU)**
- **PCU : Primary control unit (boiler management)**
- **HMI : Human Machine Interface (Display)**
- **SCU: Secondary Control Unit (D4)**

SCU : Management of a direct a mixing-valves circuit and DHW

One additional mixing valve circuit in option

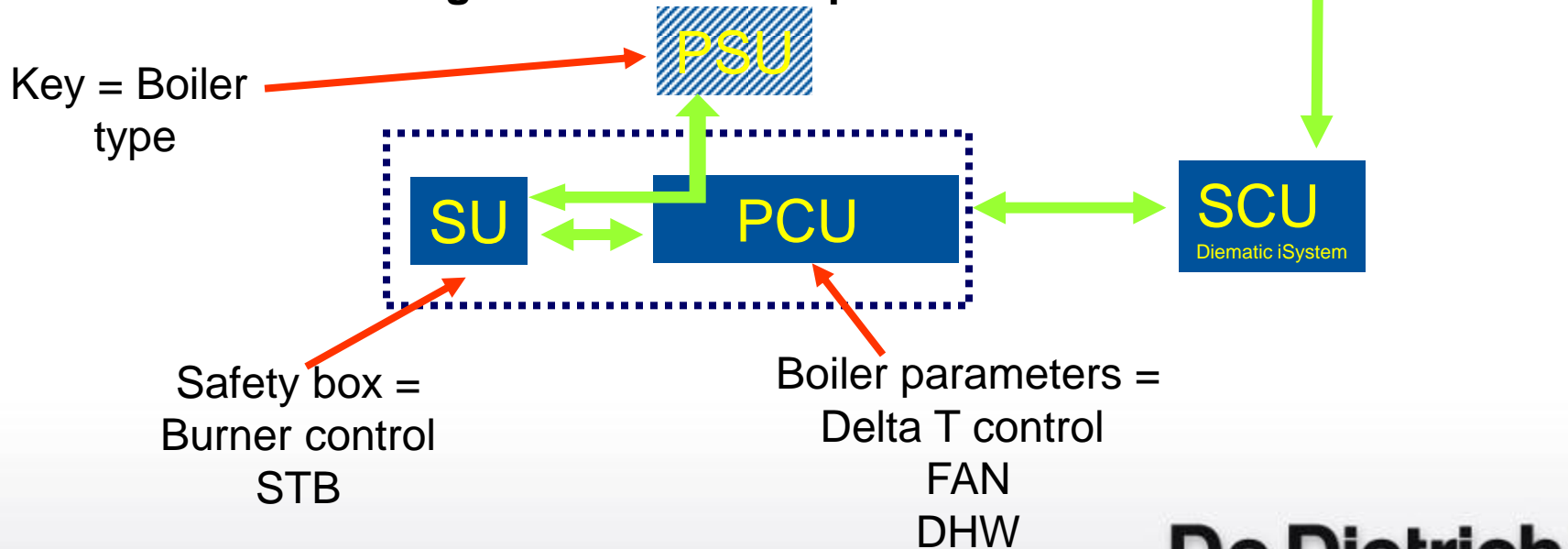

Diematic iSystem : new possibilities

More and more features:

- Control of 2 circuits (one with 3WV) and 3rd in option
- One input piloted with 0-10V
- A graphic display of the heating curve
- An accurate programming of the override duration...
- Annual vacation programme

More and more customisation

- The possibility of giving names to circuits and to generators

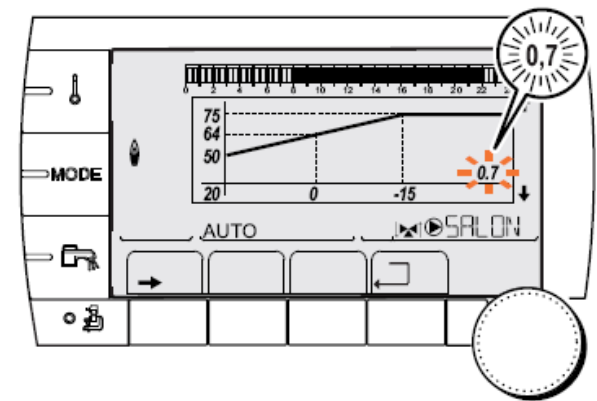
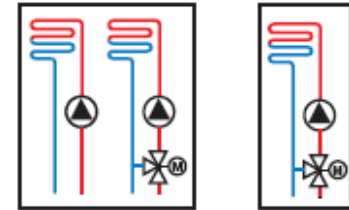

Diematic iSystem : The ergonomics

A simplicity of navigation

- New button to turn and push
- The possibility of using chapters / pages remains
- Classic or advanced installation in order to display only the useful parameters

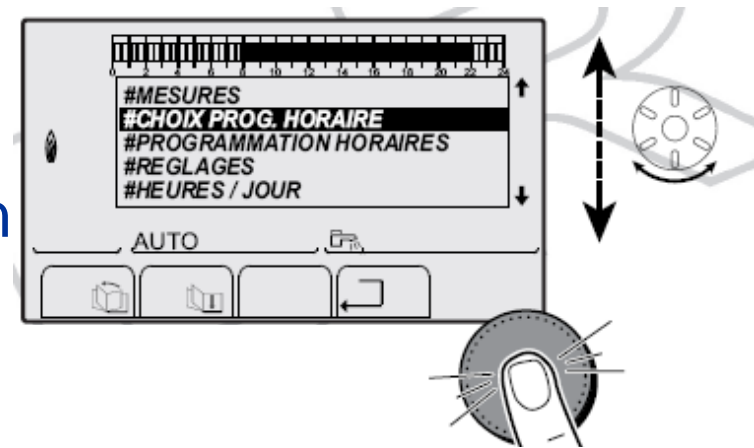

A simplicity of reading

- A clear text display on 5 lines
- A short manual explaining all the measures and the displayed parameters

Diematic iSystem :

A help to the AFTER-SALES SERVICE

Facilitate the diagnosis

- A display of the causes of the defects and the possible solutions
- A storage of the measures at the time of the defects
- A graphic display of all the measures of the last 2 hours or 24 hours

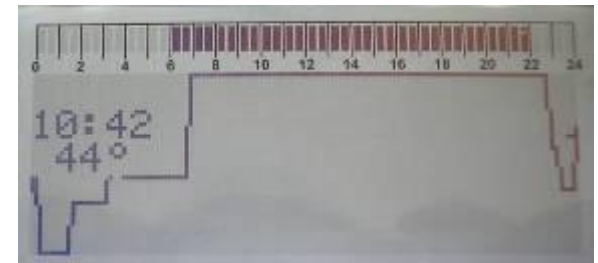

Facilitate the bond between customer and AFTER-SALES SERVICE

- The possibility of seizing the address and phone number of the AFTER-SALES SERVICE

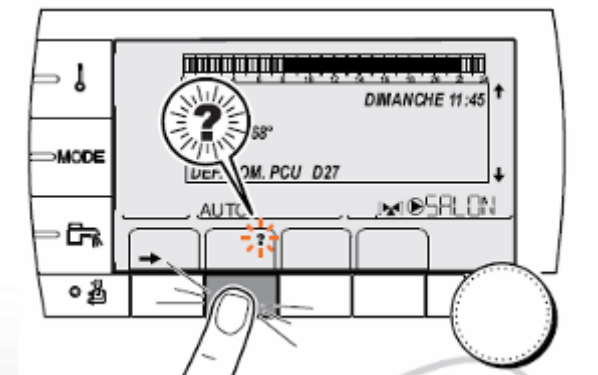

Innovens Pro MCA 45-115

Main evolutions in comparison with MC 45 -115:



SCU box (on the right) in standard execution

4.3 Implantation

Hydraulics

Installation of a MCA 45 iSystem with 1 radiators circuit + 1 circuit with mixing valve + 1 solar system DIETRISOL for DHW production, all behind the decoupling cylinder

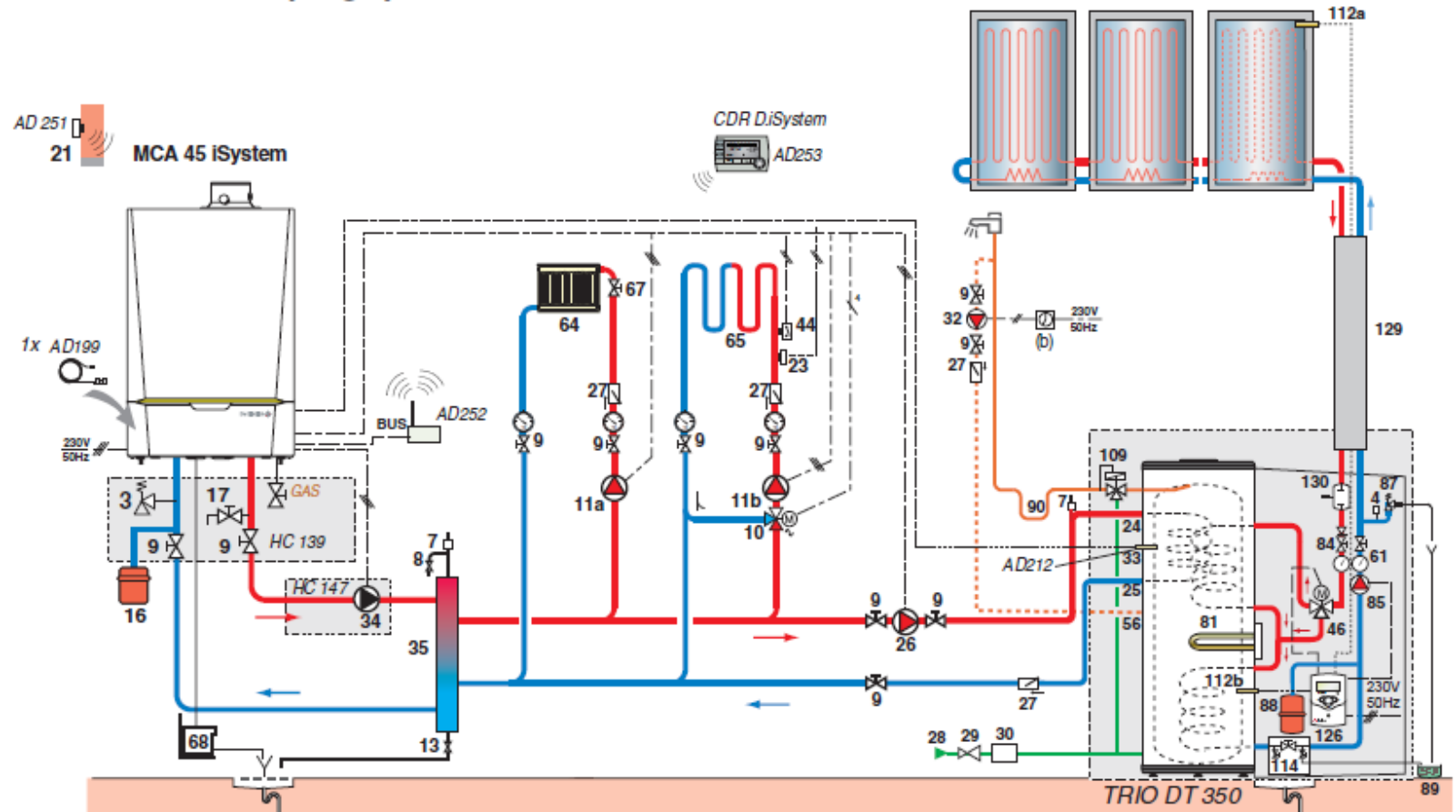

Hydraulics

⇒ iniControl CONTROL PANEL

Installation of a MCA 45 iniControl with 1 direct circuit + 1 BP/BL DHW calorifier

Outside sensor in option FM 46

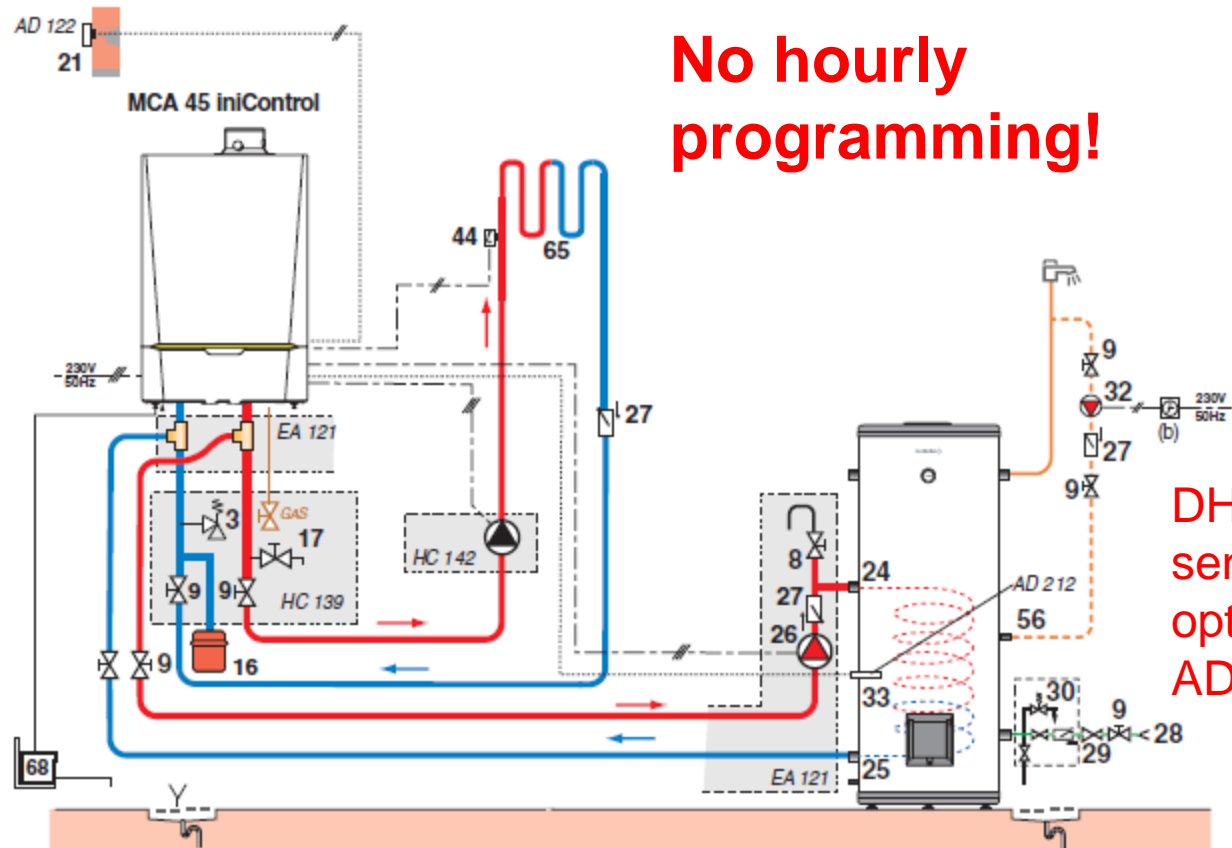

No hourly programming!

DHW sensor in option AD 212

Hydraulics

EXAMPLES OF INSTALLATIONS IN CASCADE

Installation of 3 boilers: 1 MCA... iSystem boiler and 2 MCA... iniControl boilers in cascade with 1 direct circuit + 2 circuits with mixing valve and DHW circuit

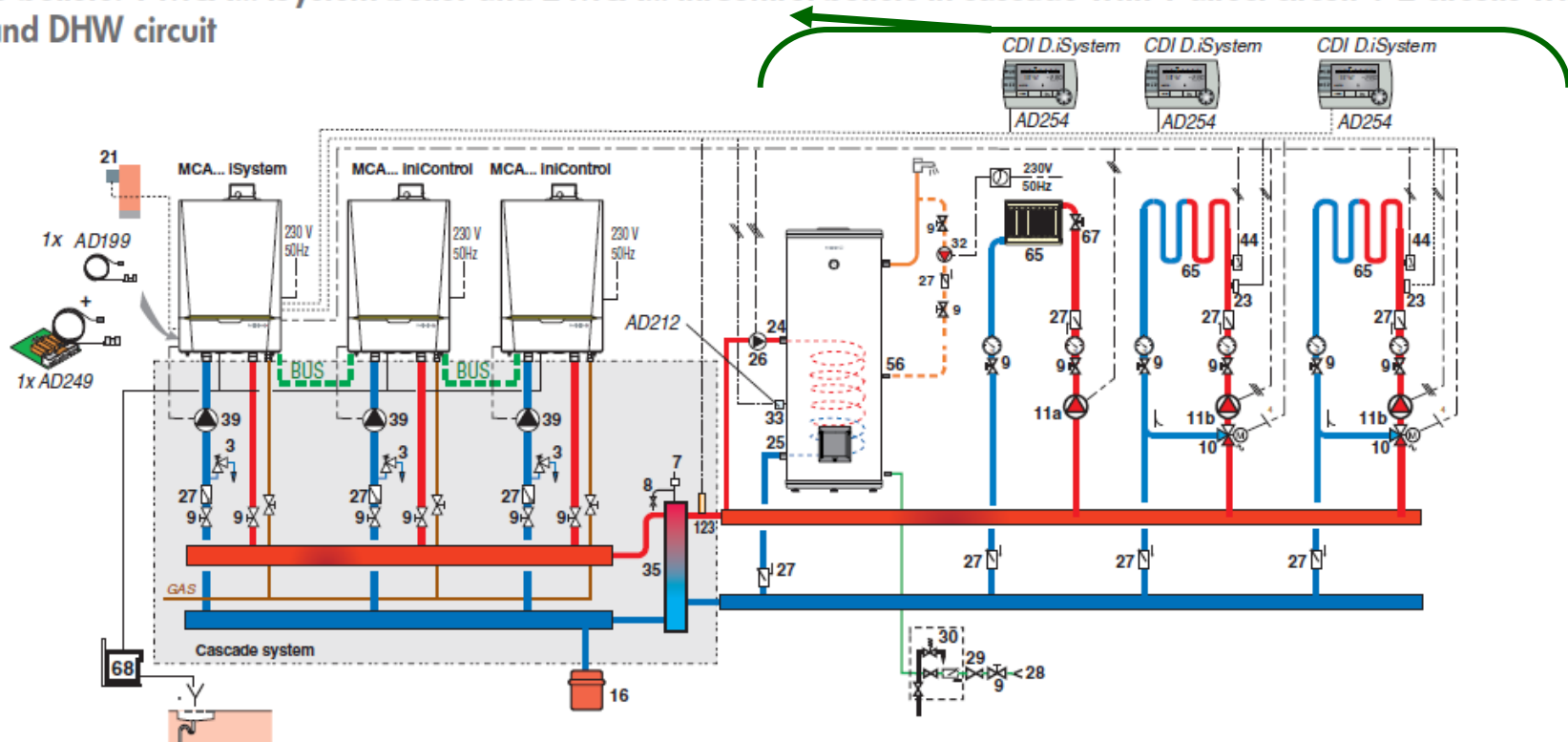

Hydraulics

Particular case of a cascade system with more than 2 secondary circuits with mixing valve:
 Installation of 4 boilers: 2 MCA... iSystem boilers and 2 MCA... iniControl boilers in cascade with 4 circuits with mixing valve

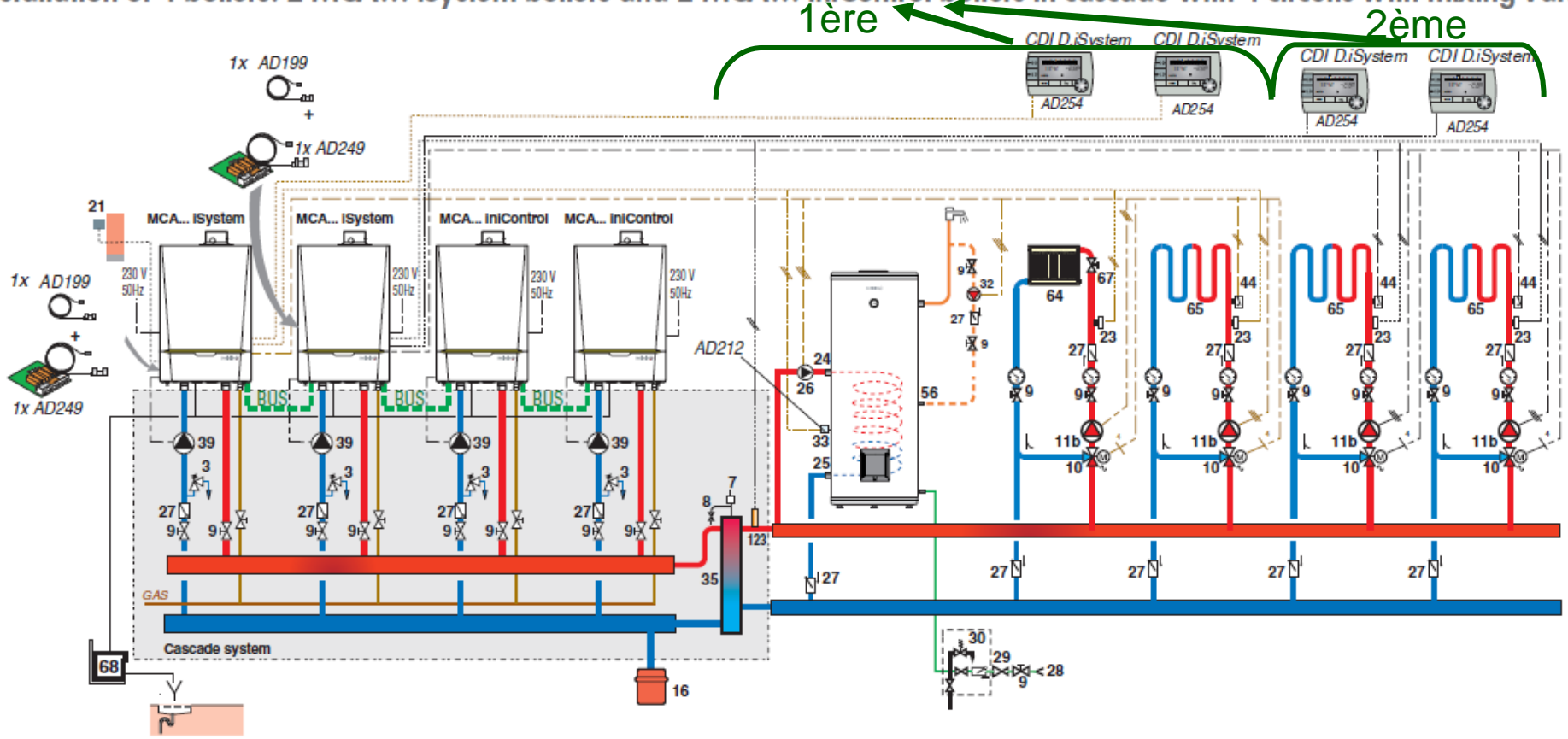

Hydraulic

IniControl

Parallel cascade

- Prog. 0-10 V identique for every boiler
- Prog. 0-10 V for the master boiler + bus cables

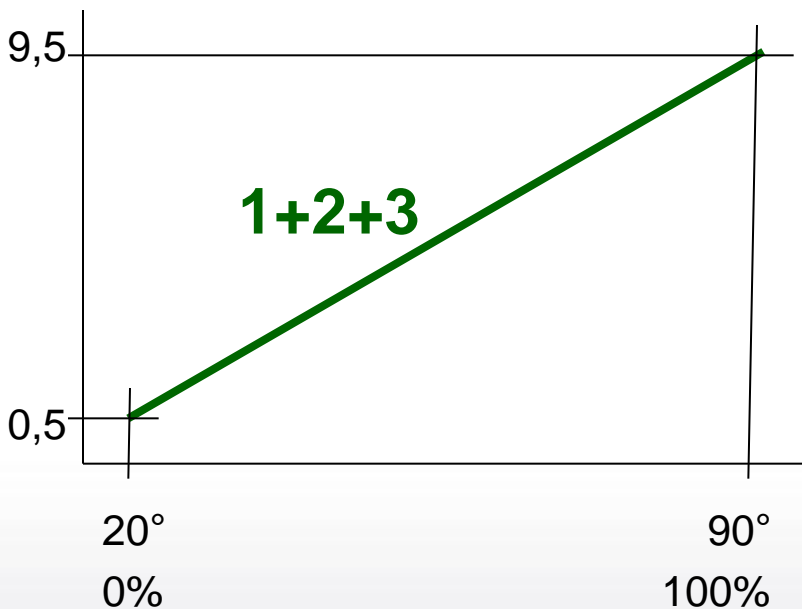

Installation of MCA... iniControl boilers in cascade

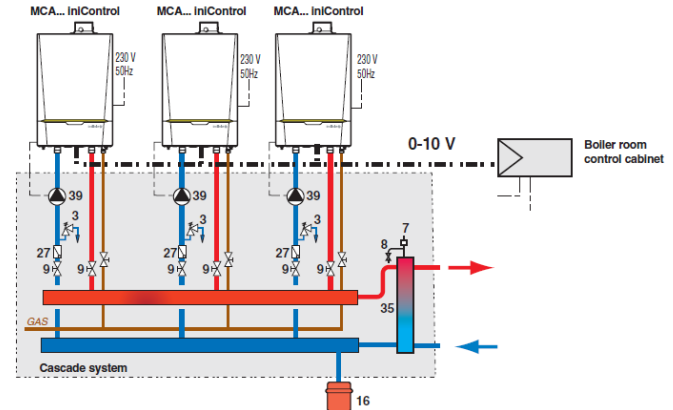

NB: In the case of a cascade installation using only MCA... iniControl boilers, the BUS cables and the cascade flow sensor delivered with the system are not used.

Classic cascade

Prog. 0-10 V Different for every boiler

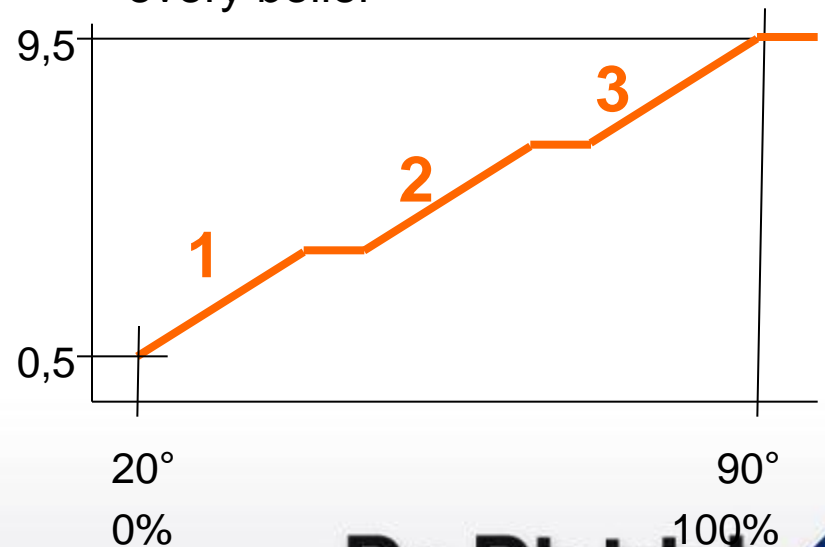

Innovens Pro MCA 45-115

**An innovation
with a tried
heat exchanger**



Questions

Answers

